

Inductors for decoupling circuits

Wound ferrite

ADL-VM series (for automotive)



AEC-Q200

ADL3225VM type



FEATURES

- Small size and thin form factor (mounting area 3.2 x 2.5 mm, height 2.5mm max.)
- Achieving broadband impedance characteristics and good DC superimposition characteristics as the result of an original coiled wiring design and original structure
- Ensuring consistent high quality and reliability as the result of a completely automated manufacturing process
- Operating temperature range: -55 to +155°C(including self-heating)
- Compliant with AEC-Q200

APPLICATION

- Inductor for use with separate signal and power lines in in-vehicle PoC (Power Over Coax)

PART NUMBER CONSTRUCTION

ADL	3225	VM	-	2R2	M	-	TL	001
Series name	LxWxH dimensions 3.2x2.5x2.5 mm	Characteristic type		Inductance (μH)	Inductance tolerance		Packaging style	Internal code

CHARACTERISTICS SPECIFICATION TABLE

L (μH)	L measuring frequency Tolerance	DC resistance (Ω)max.	Rated current*				Part No.	
			Isat (mA)typ.		Itemp (mA)typ.			
	(kHz)		105°C	125°C	105°C	125°C		
2.2	±20%	100	0.18	1050	1000	1220	1045	ADL3225VM-2R2M-TL001
15	±20%	100	0.40	350	310	725	625	ADL3225VM-150M-TL001

* Rated current: smaller value of either Isat or Itemp.

Isat: when based on the inductance change rate (30% below the nominal inductance value)

Itemp.105°C: When based on the temperature increase (temperature increase of 40°C by self heating)

Itemp.125°C: When based on the temperature increase (temperature increase of 30°C by self heating)

Measurement equipment

Measurement item	Product No. *	Manufacturer
Inductance	4294A	Keysight Technologies
DC resistance	4338A	Keysight Technologies

* Equivalent measurement equipment may be used.

ADL3225VM type

■ IMPEDANCE VS. FREQUENCY CHARACTERISTICS

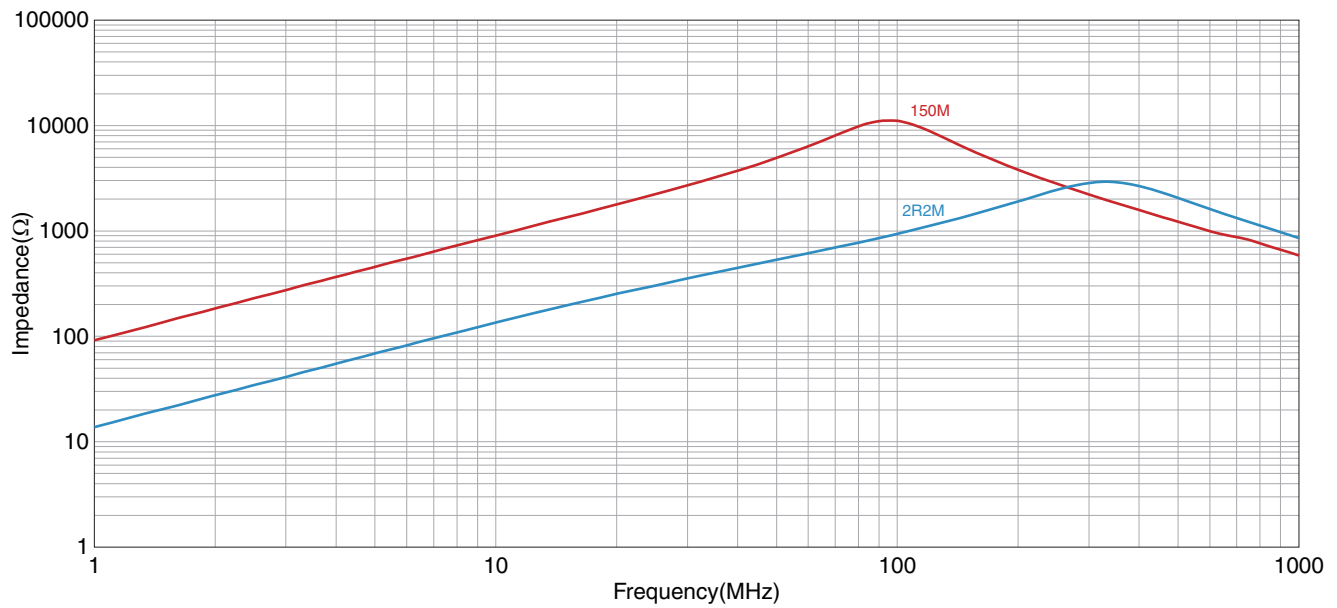

■ INDUCTANCE VS. DC BIAS CHARACTERISTICS

□ 105°C

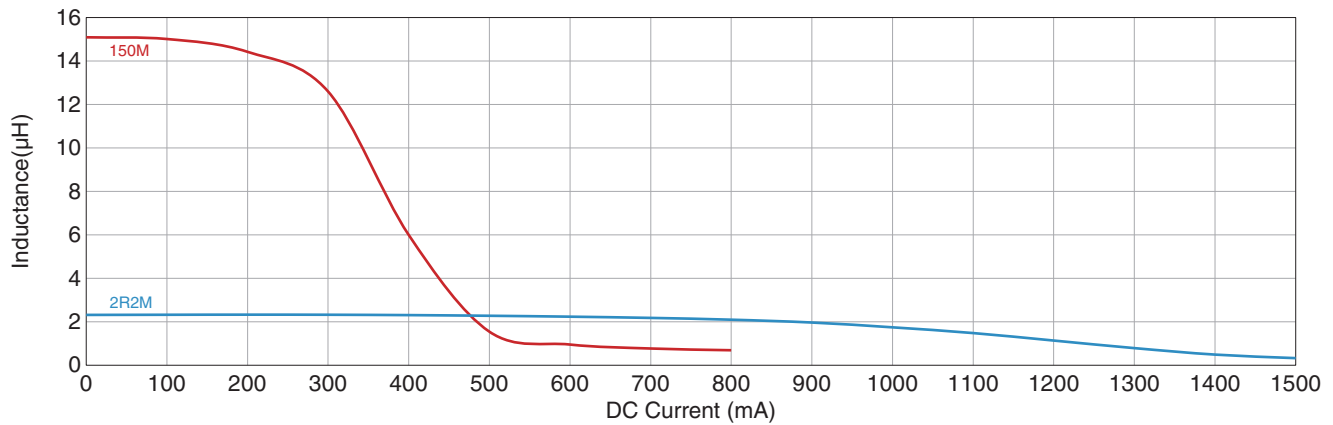

□ 125°C

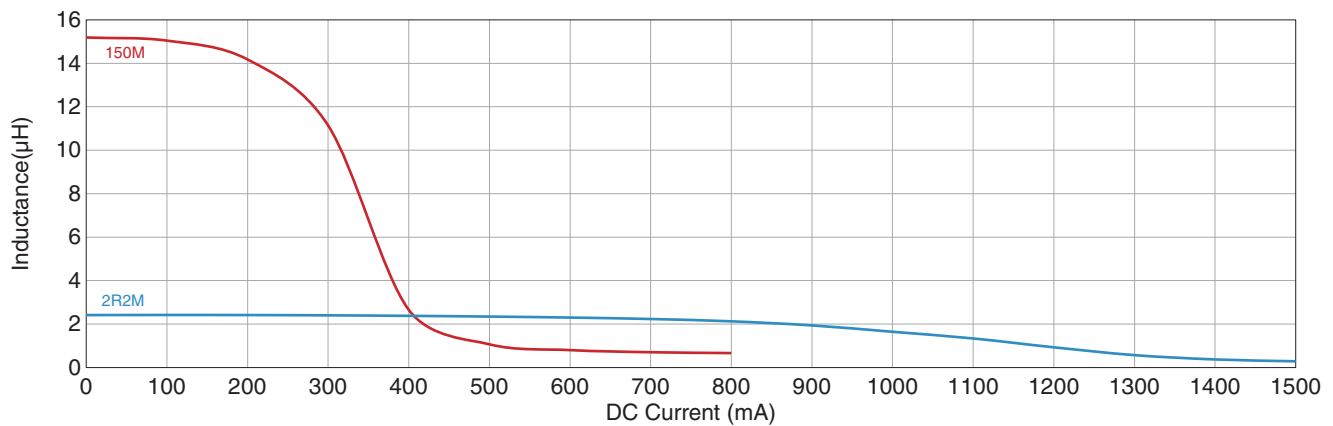

ADL3225VM type

SHAPE & DIMENSIONS

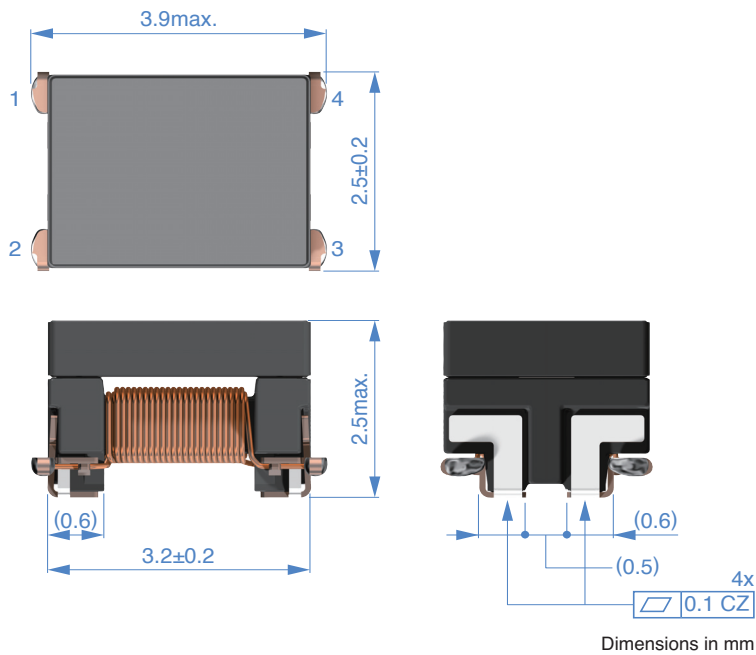

RECOMMENDED LAND PATTERN

ADL3225VM-2R2M-TL001

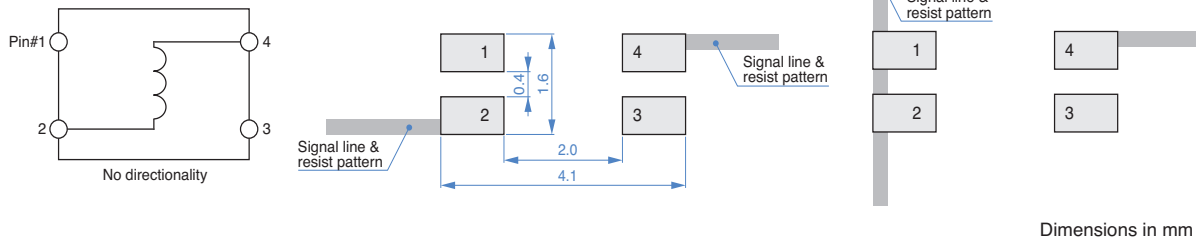

ADL3225VM-150M-TL001

ADL3225VM-150M has 4 terminals, but please connect it in a short-circuited state in the width direction and use it as a 2-terminal component.

Connect between PIN1-2 and PIN3-4 of the PCB, and cover the pattern that is not used as a footprint with a resist layer. Here is an example of a footprint connection.

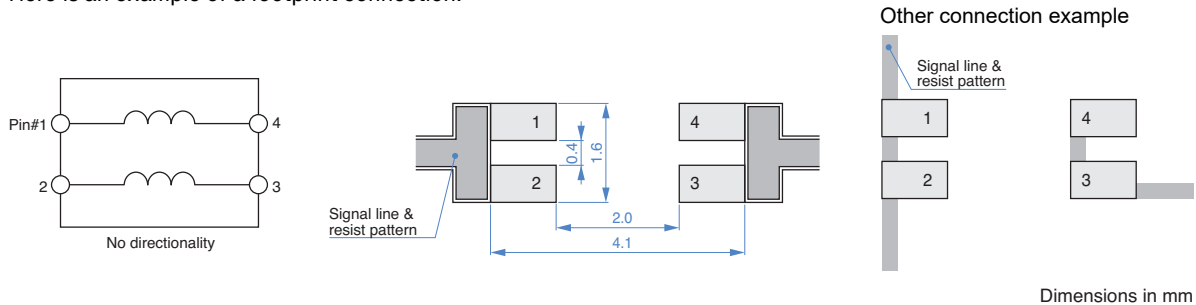

ADL3225VM type

RECOMMENDED REFLOW PROFILE

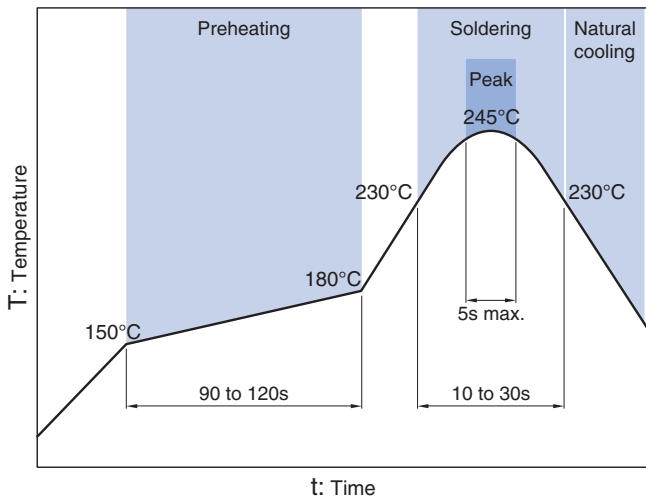

PACKAGING STYLE

REEL DIMENSIONS

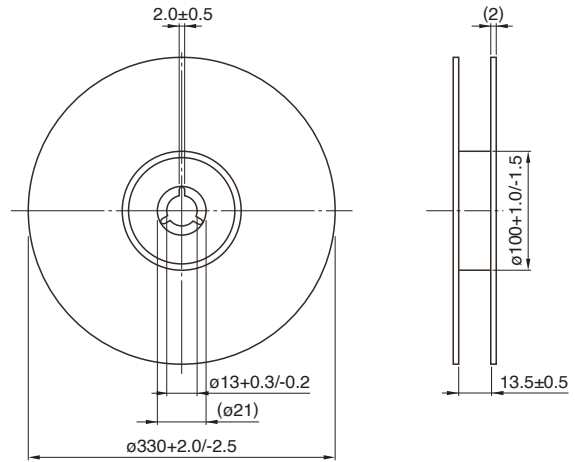

Dimensions in mm

TAPE DIMENSIONS

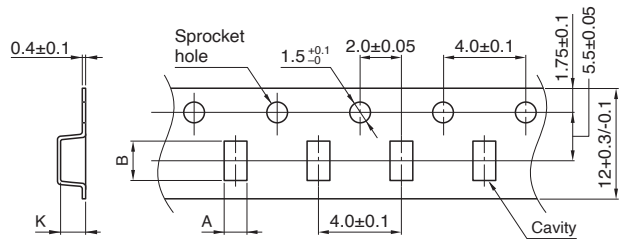

Dimensions in mm

Type	A	B	K
ADL3225VM	(2.85)	(4.2)	(2.7)

PACKAGE QUANTITY

Package quantity	6000 pcs/reel
------------------	---------------

TEMPERATURE RANGE, INDIVIDUAL WEIGHT

Operating temperature range *	Storage temperature range	Individual weight
-55 to +155 °C	-55 to +155 °C	0.076 g

* Operating temperature range includes self-heating.

REMINDERS FOR USING THESE PRODUCTS

Before using these products, be sure to request the delivery specifications.

SAFETY REMINDERS

Please pay sufficient attention to the warnings for safe designing when using this products

REMINDERS

- The storage period is within 12 months. Be sure to follow the storage conditions (temperature: 5 to 40°C, humidity: 10 to 75% RH or less).
If the storage period elapses, the soldering of the terminal electrodes may deteriorate.
- Do not use or store in locations where there are conditions such as gas corrosion (salt, acid, alkali, etc.).
- Soldering corrections after mounting should be within the range of the conditions determined in the specifications.
If overheated, a short circuit, performance deterioration, or lifespan shortening may occur.
- When embedding a printed circuit board where a chip is mounted to a set, be sure that residual stress is not given to the chip due to the overall distortion of the printed circuit board and partial distortion such as at screw tightening portions.
- Self heating (temperature increase) occurs when the power is turned ON, so the tolerance should be sufficient for the set thermal design.
- Carefully lay out the coil for the circuit board design of the non-magnetic shield type.
A malfunction may occur due to magnetic interference.
- Use a wrist band to discharge static electricity in your body through the grounding wire.
- Do not expose the products to magnets or magnetic fields.
- Do not use products that have received any excessive mechanical shock such as by being dropped.
- The performance of the product may deteriorate or at the worst case open if coating materials are used, thus please assess the situation beforehand by taking this factor into consideration.
- Due to the application of mechanical stress after mounting and handling such as contact, disconnection may occur.
- Do not use for a purpose outside of the contents regulated in the delivery specifications.
- The products listed on this specification sheet (the "Products") are intended for incorporation into automobile and/or equipment to be installed in automobile on the grounds that (i) the Products are used in accordance with the conditions and scope stated in this specification sheet and (ii) said automobile and/or equipment involving the Products are used under a normal operation and use condition.
Except for said incorporation into automobile and/or equipment installed in automobile, the Products are not designed or warranted to meet the requirements of the applications listed below, whose performance and/or quality require a more stringent level of safety or reliability, or whose failure, malfunction or trouble could cause serious damage to society, person or property. Please understand that we are not responsible for any damage or liability caused by use of the Products in any of the applications listed below or for any other use exceeding the range or conditions set forth in this specification sheet.
If you intend to use the Products beyond the condition and scope of this specification sheet or in any of the applications listed below, please contact with our sales office.
We will separately discuss with you applicable specification suitable for your intended use.

- (1) Aerospace/aviation equipment
- (2) Transportation equipment (electric trains, ships, etc.)
- (3) Medical equipment
- (4) Power-generation control equipment
- (5) Atomic energy-related equipment
- (6) Seabed equipment

- (7) Transportation control equipment
- (8) Public information-processing equipment
- (9) Military equipment
- (10) Electric heating apparatus, burning equipment
- (11) Disaster prevention/crime prevention equipment
- (12) Safety equipment
- (13) Other applications that are not considered general-purpose applications

As stated above, the Products are intended for incorporation into automobile and/or equipment to be installed in automobile, however, it is not prohibited to use the Products for general electronic equipment which is not required the same high level or reliability as automobile, or which is unlikely to damage its users' life, body and property or to cause extensive impact on society. Accordingly, all description in this specification sheet is applied if the Products are incorporated into general electronic equipment which is used for normal application under a normal operation and use condition.