

RF Inductor

BWPS Series



Overview

Wire-wound RF inductors are electronic components designed to store energy in a magnetic field when electrical current passes through them. They are constructed by winding a conductive wire (usually copper or gold-plated) around a core material such as air, ceramic, or ferrite.

This configuration allows them to provide high inductance values with minimal power loss, especially at high frequencies.

Benefits

1. High inductance value up to 1000nH
2. Shielded power inductors
3. Specially designed ferrite cover provides magnetic shielding
4. Best possible surface for pick and place handling

Applications

1. Notebook computers
2. PC cards
3. Wireless communication

Product Information

Series	Size Code (JIS/EIA)	Inductance (nH)
BWPS	3838/1515	1 ~ 1000

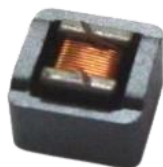

BWPS00383829 Series Specification

1 Scope: This specification applies to Wire Wound Power Chip Inductors

2 Part numbering:

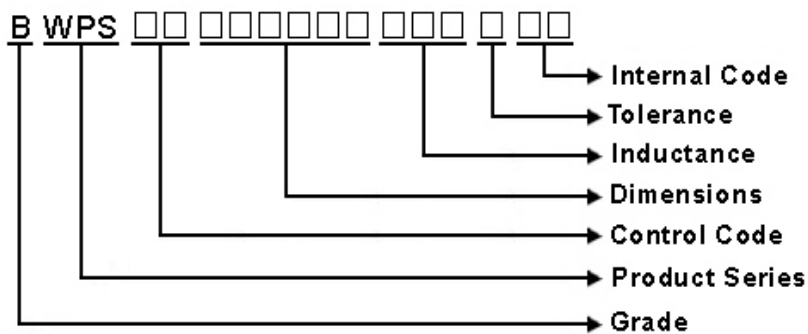

3 Rating:

Operating Temperature: - 4 0 °C ~ 1 0 5 °C

(Including self - temperature rise)

Storage Temperature: - 4 0 °C ~ 1 0 5 °C

(The storage temperature range is for after the assembly)

4 Marking:

No Marking

5 Standard Testing Condition

	Unless otherwise specified	In case of doubt
Temperature	Ordinary Temperature(15 to 35°C)	20 to 30°C
Humidity	Ordinary Humidity(25 to 85% RH)	50 to 80 %RH

BWPS00383829 Series Specification

6 Configuration and Dimensions and Unit Weight:

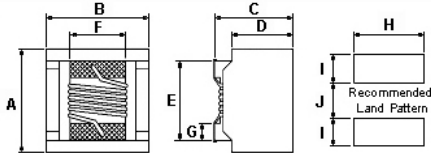

Dimensions in mm

TYPE	A	B	C	D	E	F	G	H	I	J
383829	3.81 Max.	3.81 Max.	2.94 Max.	2.2	2.54	2.03	0.51	2.54	1.02	1.27

Net Weight (grms)

SIZE CODE	Net Weight (grms)
383829	0.1364 (typ.)

7 Electrical Characteristics:

Part No.	Inductance (uH)	L/Q Test Freq. (MHZ)	Q Typ.	SRF (MHZ)Typ.	RDC (Ω)Max.	IDC (A)	Tolerance (±%)
BWPS003838291R0□00	1	0.1/1	26	344	0.05	3	20,10
BWPS003838291R5□00	1.5	0.1/1	26	260	0.08	2.8	20,10
BWPS003838291R8□00	1.8	0.1/1	28	225	0.09	2.1	20,10
BWPS003838292R2□00	2.2	0.1/1	30	228	0.14	1.5	20,10
BWPS003838292R7□00	2.7	0.1/1	30	185	0.14	1.5	20,10
BWPS003838293R9□00	3.9	0.1/1	30	172	0.29	1.2	20,10
BWPS003838294R7□00	4.7	0.1/1	30	157	0.35	1.1	20,10
BWPS003838295R6□00	5.6	0.1/1	30	150	0.39	1.1	20,10
BWPS003838296R8□00	6.8	0.1/1	30	110	0.58	0.9	20,10
BWPS00383829100□00	10	0.1/1	30	95	0.75	0.82	20,10
BWPS00383829150□00	15	0.1/1	30	75	1.15	0.7	20,10
BWPS00383829220□00	22	0.1/1	33	30	1.4	0.65	20,10
BWPS00383829330□00	33	0.1/1	33	21	1.61	0.52	20,10
BWPS00383829390□00	39	0.1/1	33	18	1.85	0.46	20,10
BWPS00383829470□00	47	0.1/1	33	15	2.2	0.43	20,10
BWPS00383829680□00	68	0.1/1	33	12	3.8	0.33	20,10
BWPS00383829820□00	82	0.1/1	33	10	4.3	0.32	20,10
BWPS00383829101□00	100	0.1/1	33	8	4.8	0.31	20,10
BWPS00383829121□00	120	0.1/1	33	8	5	0.25	20,10
BWPS00383829151□00	150	0.1/1	33	5.8	6.5	0.24	20,10
BWPS00383829221□00	220	0.1/1	33	5.5	12	0.22	20,10
BWPS00383829331□00	330	0.1/1	33	3.8	17	0.2	20,10
BWPS00383829561□00	560	0.1/1	33	2.8	18.4	0.13	20,10
BWPS00383829681□00	680	0.1/1	33	2.5	24	0.12	20,10
BWPS00383829821□00	820	0.1/1	23	2	26	0.1	20,10
BWPS00383829102□00	1000	0.1/1	20	1.5	29.2	0.1	20,10

NOTE: □-tolerance K=±10% / M=±20%

1. Operating temperature range - 4 0 °C ~ 1 0 5 °C
2. L/Q Test OSC @100mV.
3. IDC for Inductance drop 10% from its value without current.

BWPS00383829 Series Specification

8 BWPS00383829 Series

8.1 Construction:

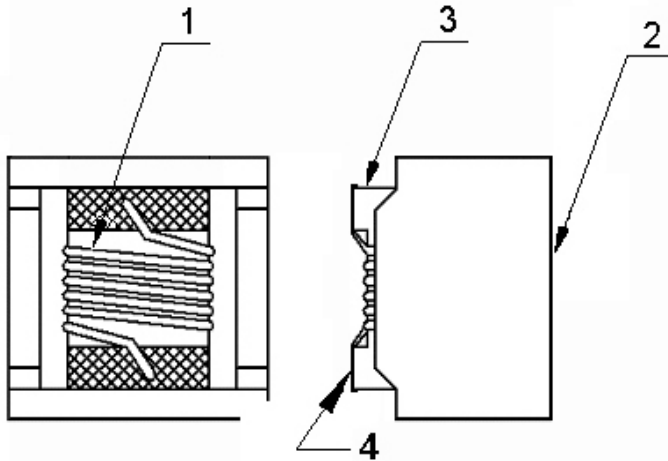

8.2 Material List:

NO	PART	MATERIAL
1	WIRE	Grade 180
2	COVER SHEET	FERRITE CORE
3	CORE	FERRITE CORE
4	TERMINAL	Ag/Cu/Ni/Sn

BWPS00383829 Series Specification

9 Reliability Of Wire Wound Power Chip Inductor

1-1.Environmental Performance

No	Item	Specification	Test Method															
1-1-1	Temperature Cycle	Appearance: No Damage Inductance: within $\pm 10\%$ of initial value Q change: within $\pm 30\%$ of initial value	One cycle: <table border="1"> <thead> <tr> <th>Step</th> <th>Temperature ($^{\circ}\text{C}$)</th> <th>Time (min)</th> </tr> </thead> <tbody> <tr> <td>1</td> <td>-40 ± 3</td> <td>30</td> </tr> <tr> <td>2</td> <td>25 ± 2</td> <td>3</td> </tr> <tr> <td>3</td> <td>105 ± 3</td> <td>30</td> </tr> <tr> <td>4</td> <td>25 ± 2</td> <td>3</td> </tr> </tbody> </table> Total: 5 cycles Measured After Exposure in The Room Condition For 1hrs	Step	Temperature ($^{\circ}\text{C}$)	Time (min)	1	-40 ± 3	30	2	25 ± 2	3	3	105 ± 3	30	4	25 ± 2	3
Step	Temperature ($^{\circ}\text{C}$)	Time (min)																
1	-40 ± 3	30																
2	25 ± 2	3																
3	105 ± 3	30																
4	25 ± 2	3																
1-1-2	High Temperature Resistance		Temperature: $105\pm 3^{\circ}\text{C}$ Time: 1000Hrs Measured After Exposure In The Room Condition For 1Hrs															
1-1-3	Low Temperature Resistance		Temperature: $-40\pm 3^{\circ}\text{C}$ Time: 1000Hrs Measured After Exposure In The Room Condition For 1Hrs															
1-1-4	Humidity Load Life	There should be no evidence of short or open circle	Temperature: $40\pm 2^{\circ}\text{C}$ Relative Humidity: 90~95% Load: Allowed DC Current Time: 96Hrs															

1-2.Mechanical Performance

No	Item	Specification	Test Method
1-2-1	Resistance TO Soldering Heat	Appearance: No Damage	1. The device should be reflow soldered on PCB (peak $260^{\circ}\text{C} \pm 5^{\circ}\text{C}$ for 10 seconds) 2. Solder Composition: Sn/Ag3.0/Cu0.5 3. Test time: 6 minutes
1-2-2	Solder ability	The electrodes shall be at least 95% covered with new solder coating	1. Pre-Heating: 150°C , 1min. 2. Solder Composition: Sn/Ag3.0/Cu0.5 3. Solder Temperature: $245\pm 5^{\circ}\text{C}$. 4. Immersion Time: 4 ± 1 sec.
1-2-3	Component Adhesion (Push Test)	1 Lbs. For 0603 2 Lbs. For 0805 4 Lbs. For The Rest	The device should be reflow soldered ($245\pm 5^{\circ}\text{C}$ For 10 seconds) to a tinned copper substrate. A force gauge should be applied to the side of the component. The device must withstand a minimum force of 1or2or4 pounds without a failure of the termination attached to component

BWPS00383829 Series Specification

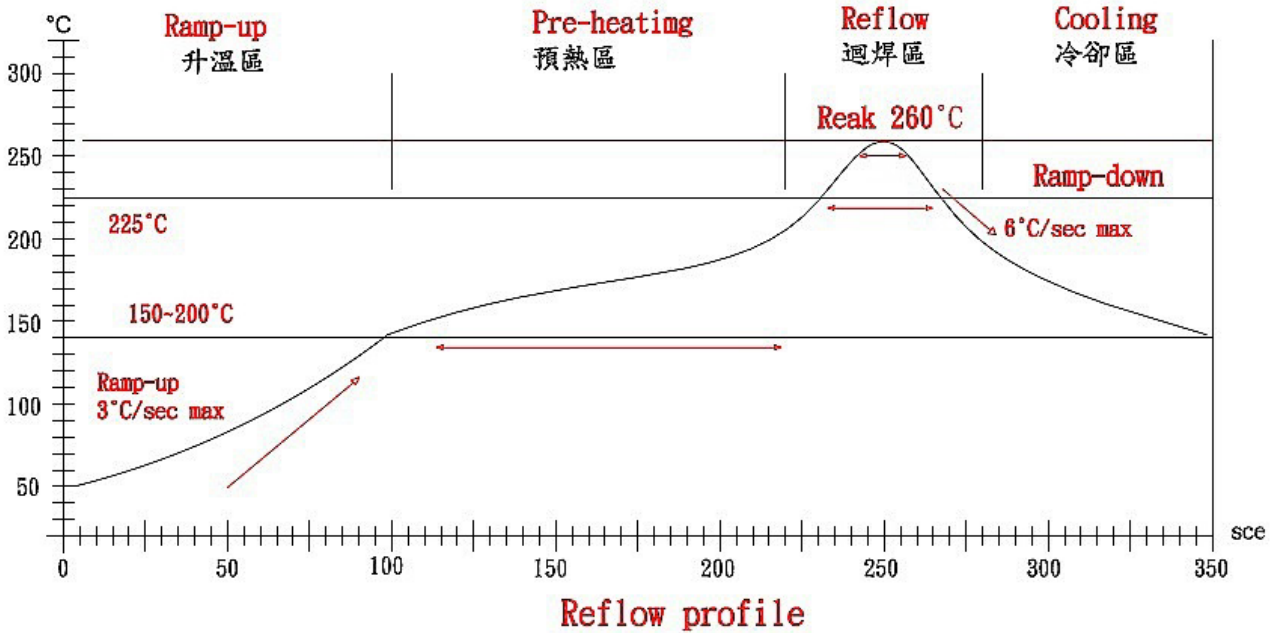

Lead-Free(LF)標準溫度分析範圍

Refer to J-STD-020C

管制項目 Item.	升温區 Ramp-up	預熱區 Pre-heating	迴焊區 Reflow	Peak Temp	冷卻區 Cooling
溫度範圍 Temp.scope	R.T ~ 150°C	150°C ~ 200°C	Above 217°C	260±5°C	Peak Temp.~150°C
標準時間 Time spec.	-	60 ~ 180 sec	60 ~ 150 sec	20 ~ 40 sec	-
實際時間 Time result	-	75 ~ 100 sec	90 ~ 120 sec	20 ~ 35 sec	-

NOTE :

1. Re-flow possible times : within 2 times
2. Nitrogen adopted is recommended while in re-flow
3. Products can only be soldered with reflow

BWPS00383829 Series Specification

10 Packaging:

10.1 Packaging -Cover Tape

The force for tearing off cover tape is 10 to 130 grams in the arrow direction.

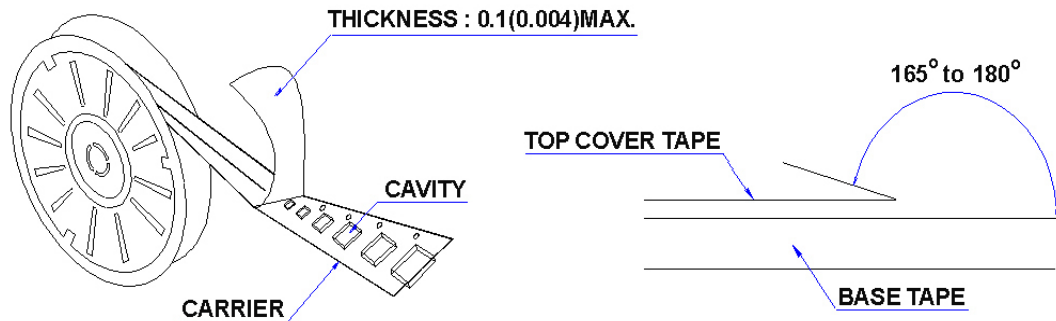

10.2 Packaging Quantity

TYPE	PCS/REEL
383829	750

10.3 Reel Dimensions

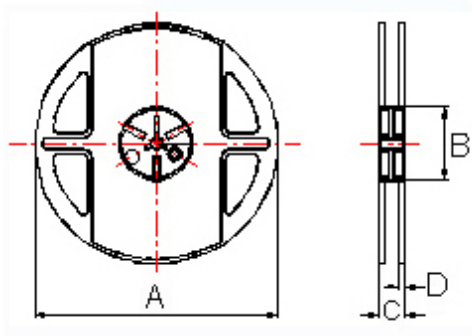

Dimensions in mm

TYPE	A	B	C	D
383829	178±1	60±0.5	16±0.5	1.4±0.5

BWPS00383829 Series Specification

10 Packaging:

10.4 Tape Dimensions in mm

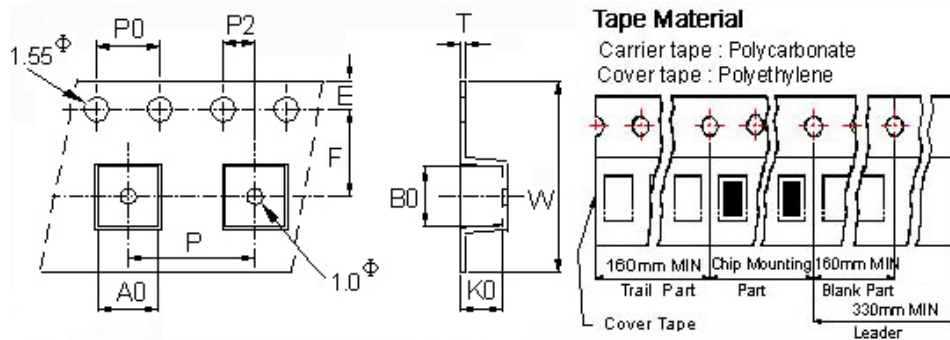

TYPE	A0	B0	K0	E	F	W	T	P	P0	P2
383829	3.85	3.85	2.9	1.75	5.5	12	0.25	8	4	2

11 Recommended Land Pattern:

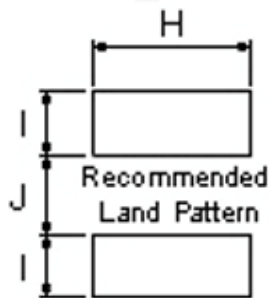

Dimensions in mm

TYPE	H(In/mm)	I(In/mm)	J(In/mm)
383829	0.1/2.54	0.04/1.02	0.05/1.27

12 Note:

- Please make sure that your product has been evaluated and confirmed against your specifications when our product is mounted to your product.
- Do not knock nor drop.
- All the items and parameters in this product specification have been prescribed on the premise that our product is used for the purpose, under the condition and in the environment agreed upon between you and us. You are requested not to use our product deviating from such agreement.
- The storage period is less than 12 months. Be sure to follow the storage conditions (Temperature: 5 to 40°C, Humidity: 10 to 75% RH or less).
If the storage period elapses, the soldering of the terminal electrodes may deteriorate.
- Do not use or store in locations where there are conditions such as gas corrosion (salt, acid, alkali, etc.).
- The moisture sensitivity level (MSL) of products is classified as level 1.

BWPS00383829 Series Specification

13 Graph:

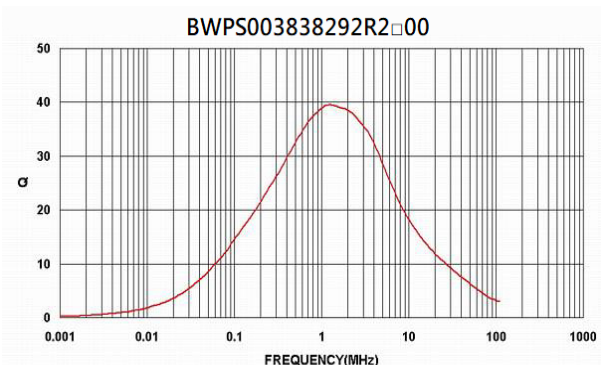
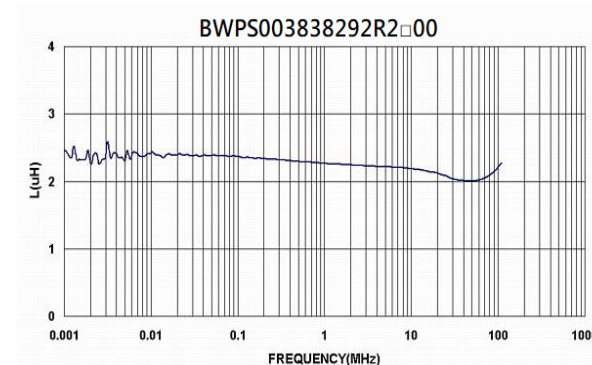
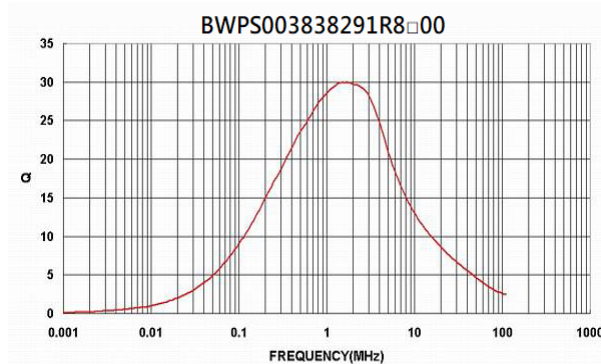
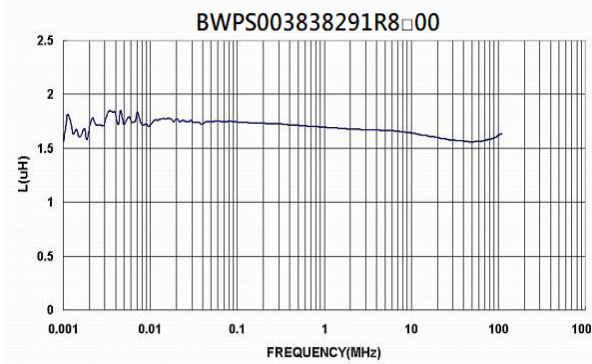
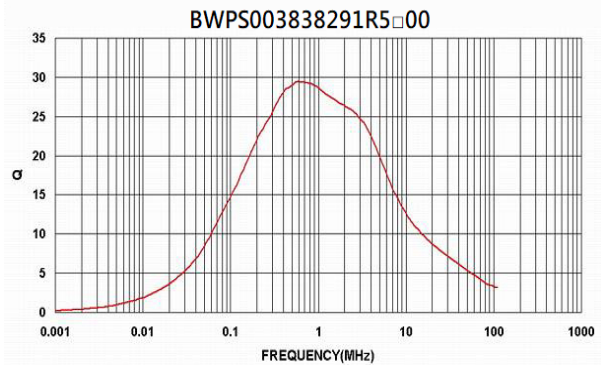
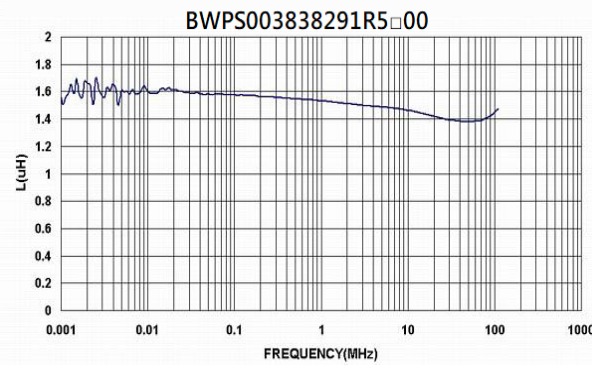
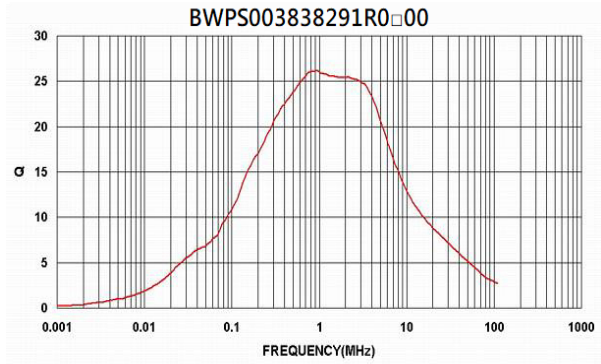
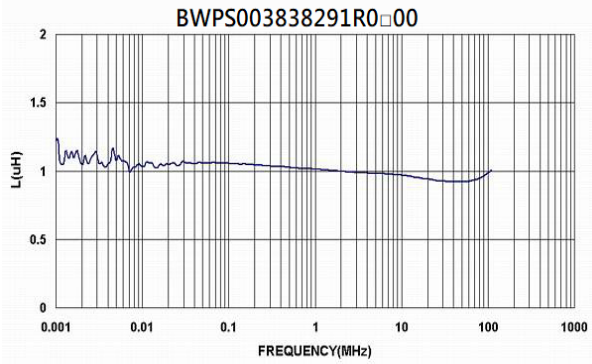

BWPS00383829 Series Specification

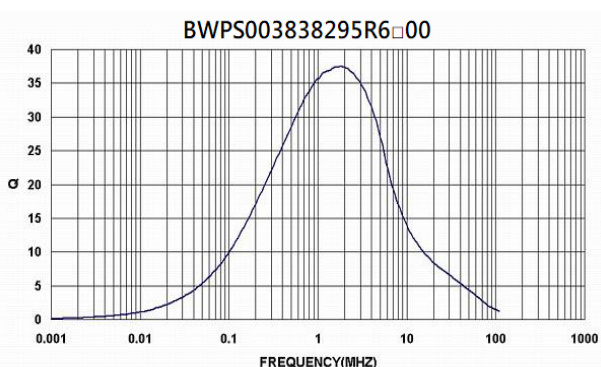
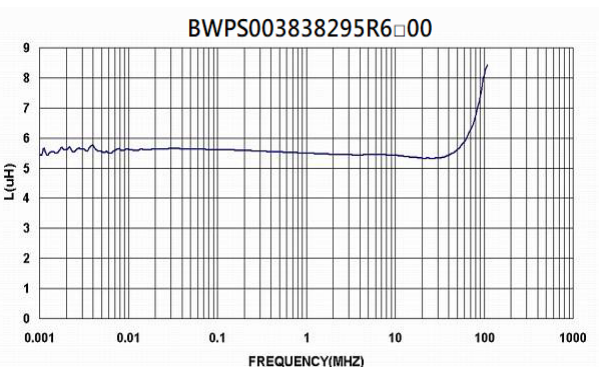
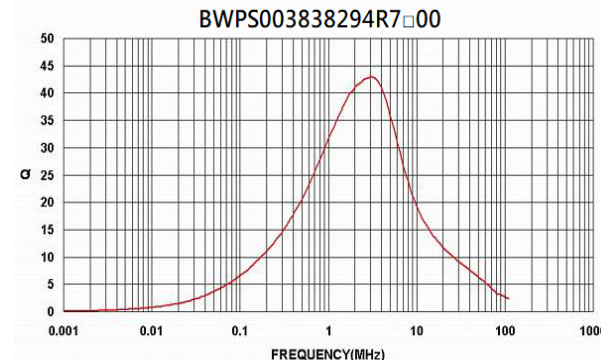
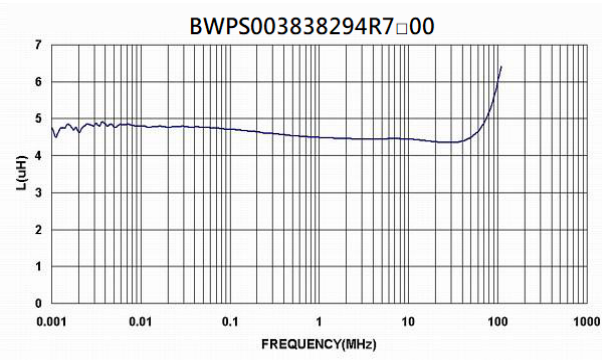
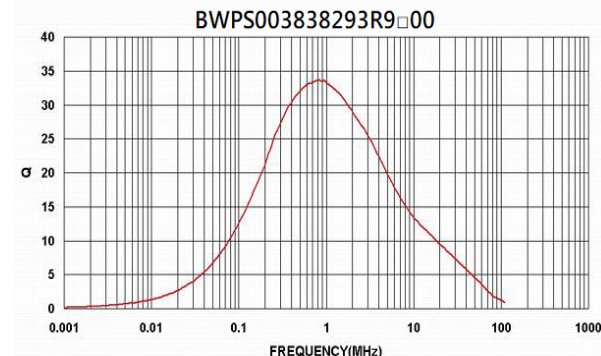
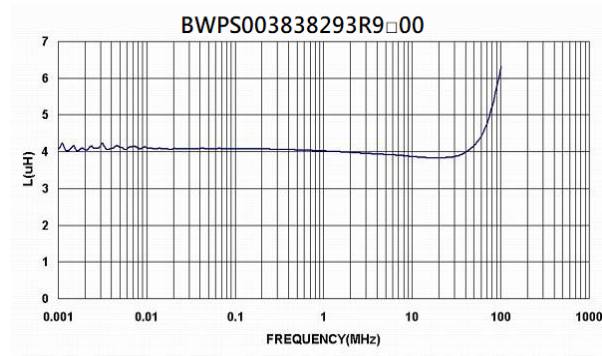
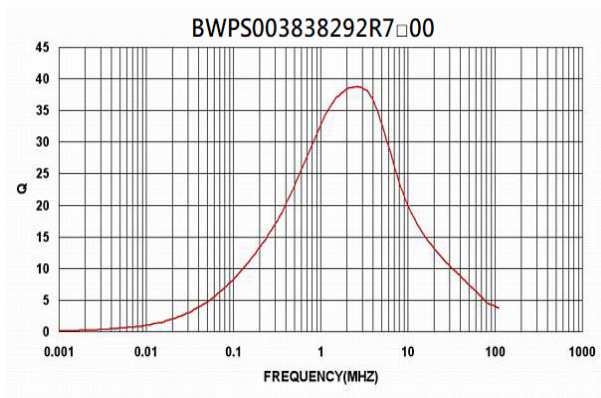
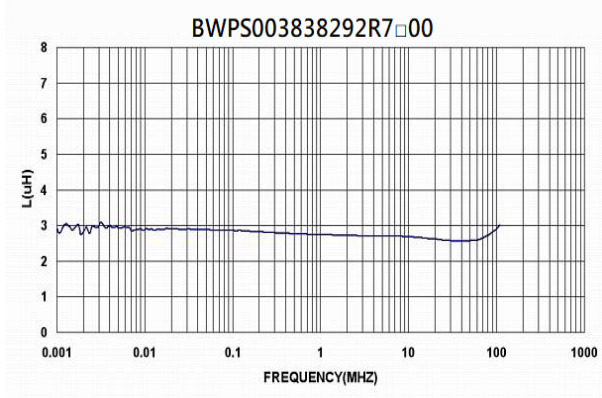

BWPS00383829 Series Specification

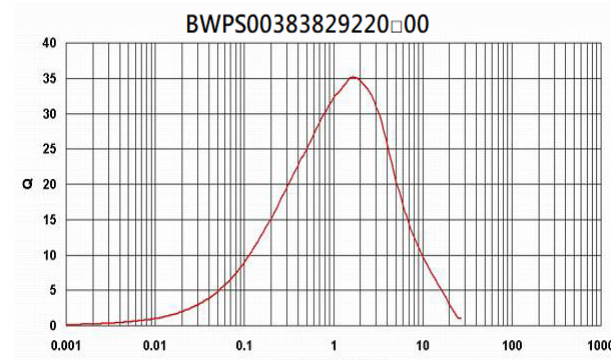
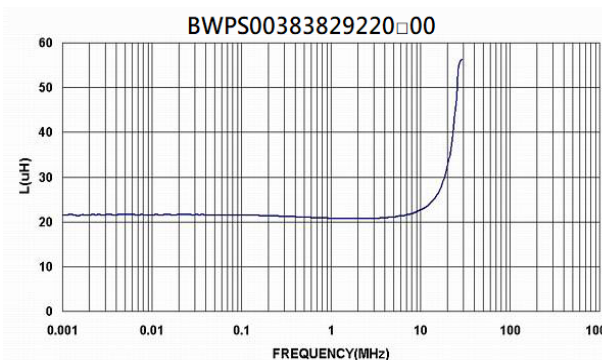
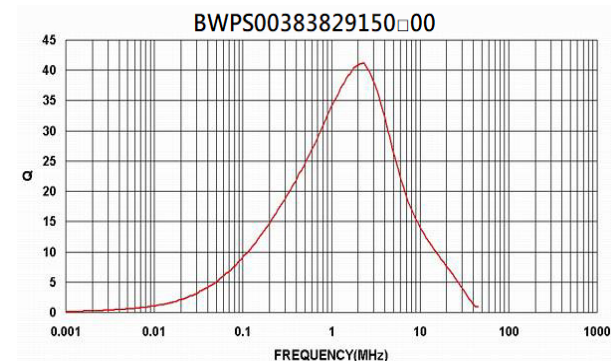
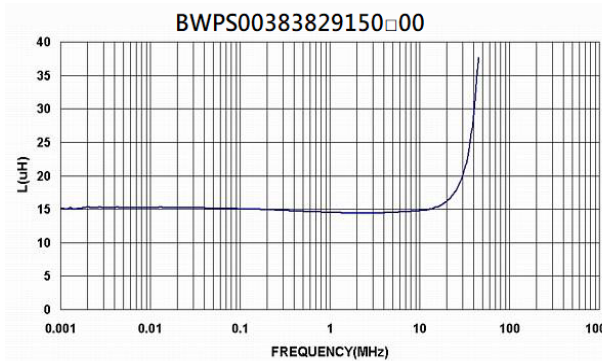
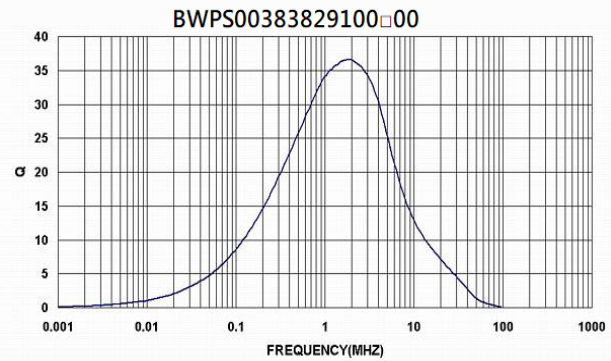
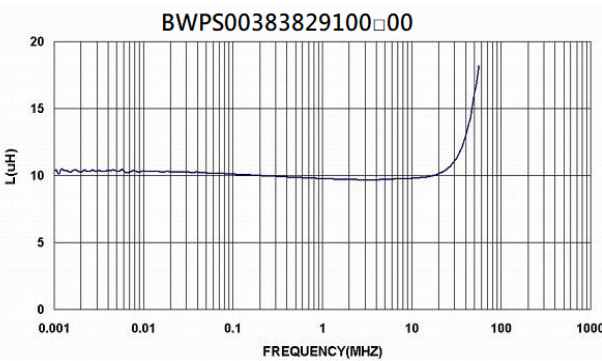
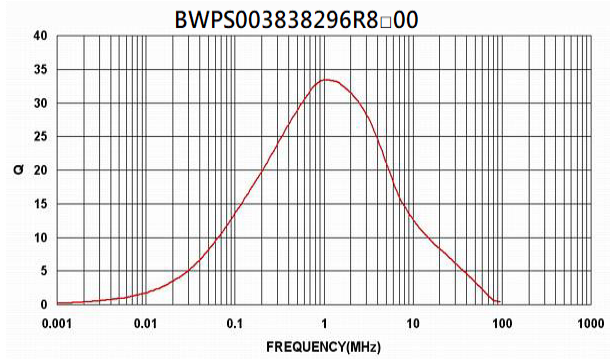
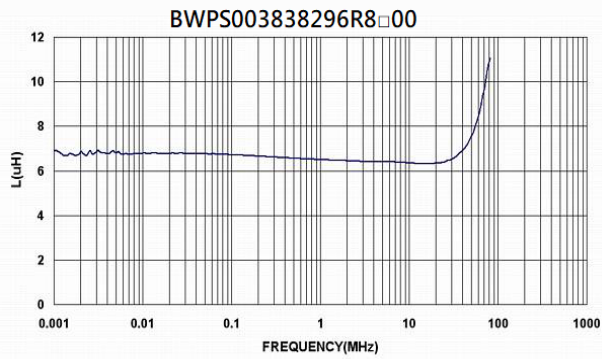

BWPS00383829 Series Specification

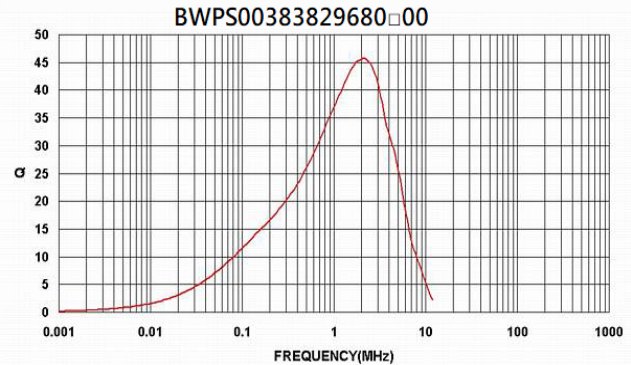
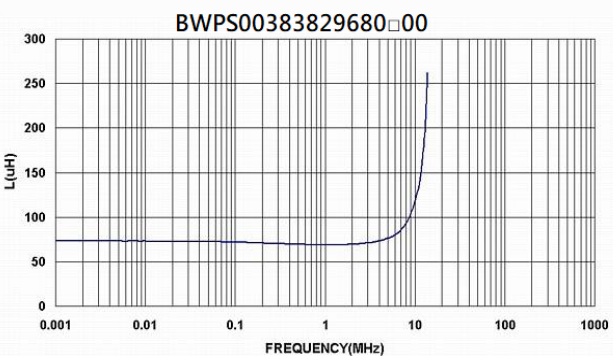
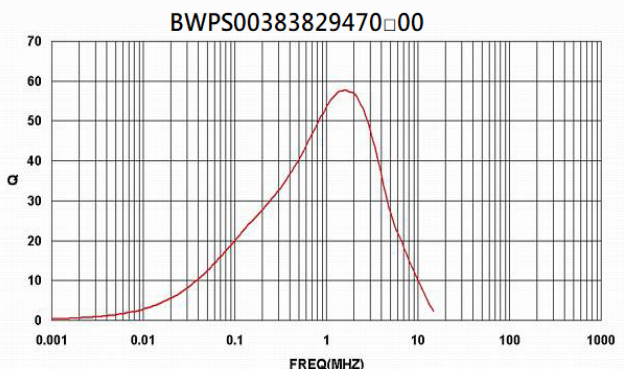
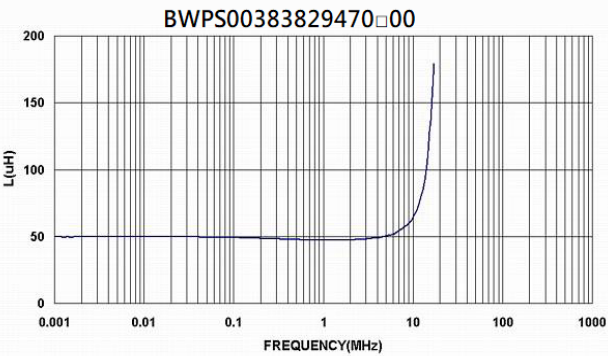
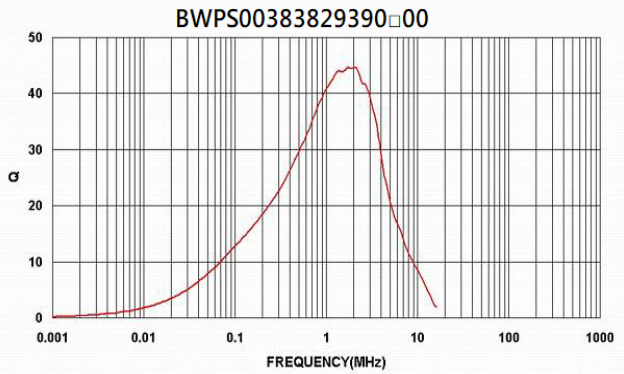
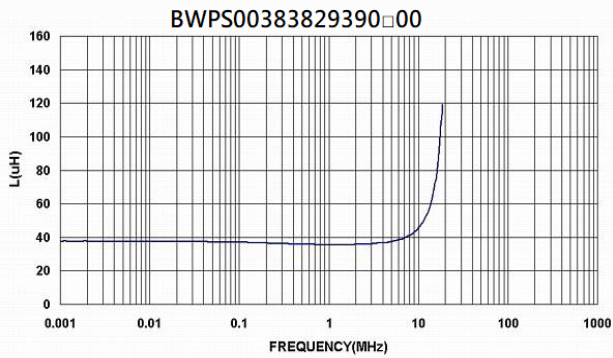
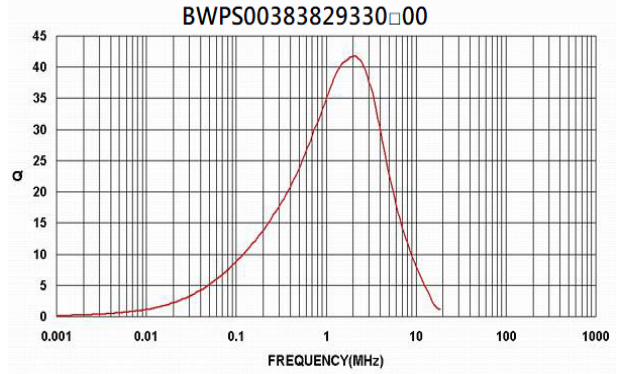
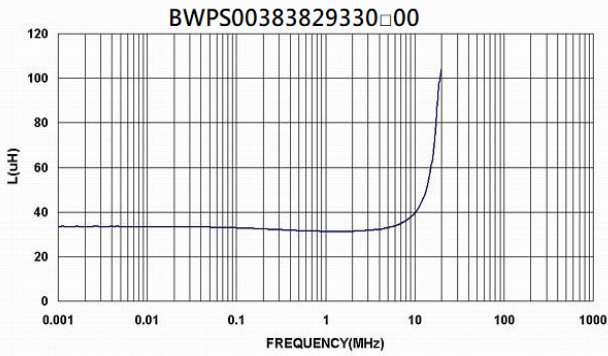

BWPS00383829 Series Specification

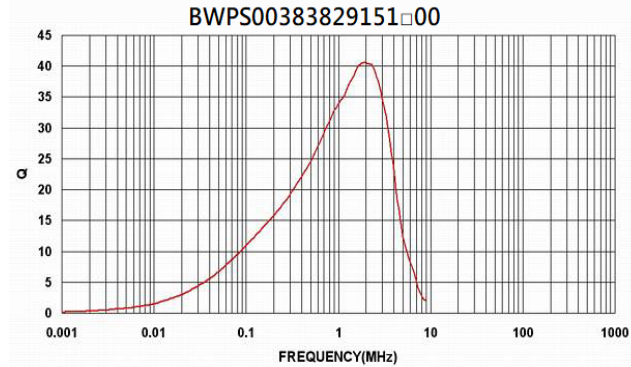
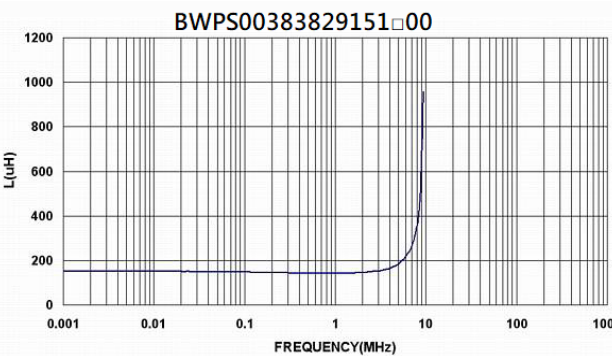
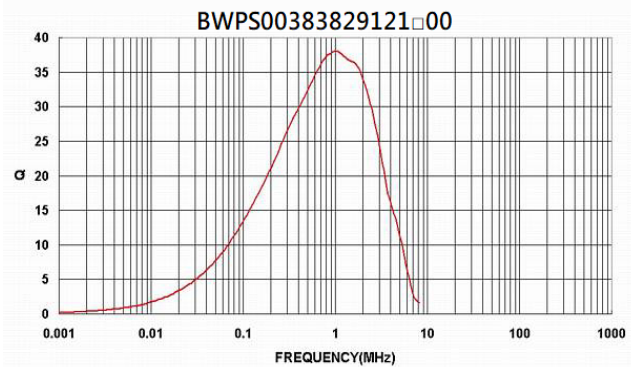
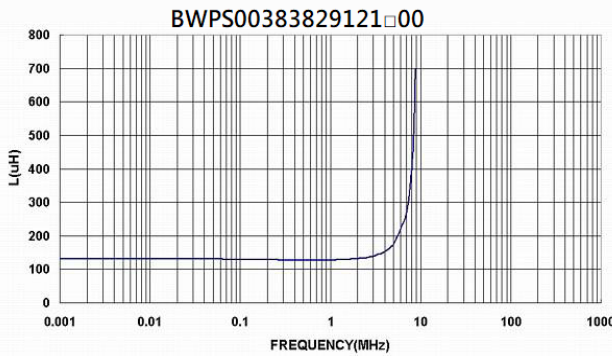
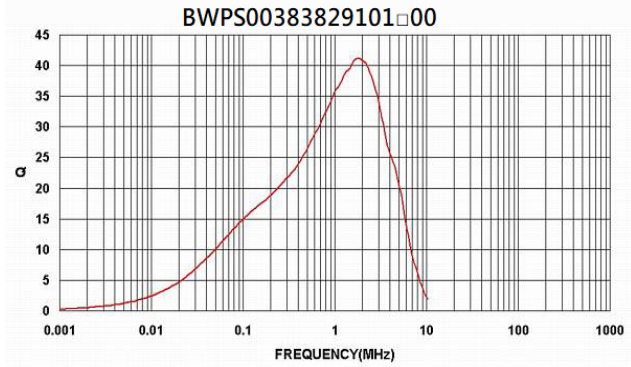
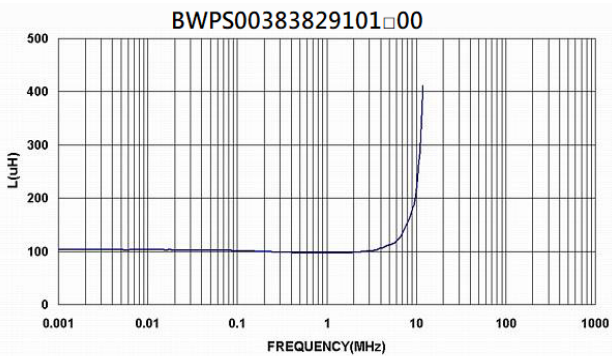
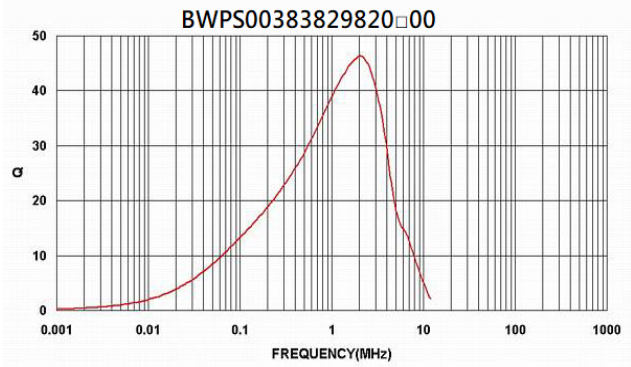
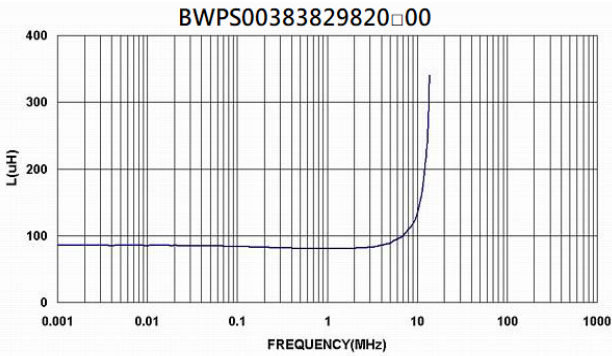

BWPS00383829 Series Specification

