

RF Inductor

BWNL Series



Overview

Wire-wound RF inductors are electronic components designed to store energy in a magnetic field when electrical current passes through them. They are constructed by winding a conductive wire (usually copper or gold-plated) around a core material such as air, ceramic, or ferrite.

This configuration allows them to provide high inductance values with minimal power loss, especially at high frequencies.

Benefits

1. Superior Q characteristics and the broadest L selections
2. Strong solderability by reflow soldering and soldering iron
3. Terminals are highly resistant to external forces
4. Highly reliable in environments of sudden temperature change and humidity

Applications

1. Consumer electronics
2. LCD TV
3. Game console

Product Information

Series	Size Code (JIS/EIA)	Inductance (nH)
BWNL	2016/0805 2520/1008	0.005 ~ 100



BWNL00241715 Series Specification

1 Scope: This specification applies to Wire Wound Ferrite Chip Inductors

2 Part numbering:

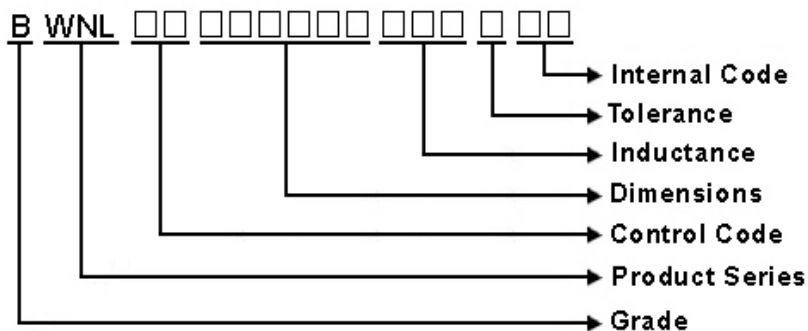

3 Rating:

Operating Temperature: - 40°C ~ 105°C
(Including self - temperature rise)

Storage Temperature: -40°C ~ 105°C
(The storage temperature range is for after the assembly)

4 Marking:

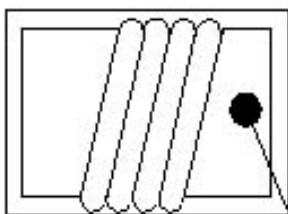

Ex Marking: 1st → Red

5 Standard Testing Condition

	Unless otherwise specified	In case of doubt
Temperature	Ordinary Temperature(15 to 35°C)	20 to 30°C
Humidity	Ordinary Humidity(25 to 85% RH)	50 to 80 %RH

BWNL00241715 Series Specification

6 Configuration and Dimensions and Unit Weight:

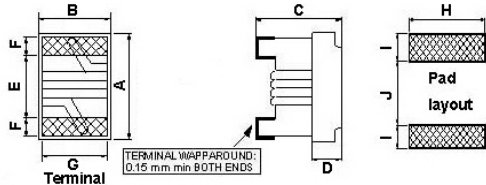

Dimensions in mm

TYPE	A	B	C	D	E	F	G	H	I	J
241715	2.40 Max.	1.72 Max.	1.52 Max.	0.7	1.02	0.50	1.27	1.78	1.02	0.76

Net Weight (grms)

SIZE CODE	Net Weight (grms)
241715	0.0129 (typ.)

7 Electrical Characteristics:

Part No.	Inductance (uH)	Test Freq. (MHz)	Q Min.	SRF (MHz)Min.	RDC (Ω)Max.	IDC (mA)	Tolerance (±%)	Color Code 1st
BWNL00241715R12□00	0.12	5,10	25	500	0.2	600	5,10	WHT
BWNL00241715R15□00	0.15	5,10	25	450	0.25	600	5,10	BLK
BWNL00241715R18□00	0.18	5,10	25	410	0.3	570	5,10	BRN
BWNL00241715R22□00	0.22	5,10	25	350	0.35	550	5,10	RED
BWNL00241715R27□00	0.27	5,10	25	280	0.4	530	5,10	ORN
BWNL00241715R33□00	0.33	5,10	25	235	0.45	510	5,10	YEL
BWNL00241715R39□00	0.39	5,10	25	210	0.5	490	5,10	GRN
BWNL00241715R47□00	0.47	5,10	25	170	0.55	470	5,10	BLU
BWNL00241715R56□00	0.56	5,10	25	150	0.6	450	5,10	VIO
BWNL00241715R68□00	0.68	5,10	25	140	0.7	420	5,10	GRY
BWNL00241715R82□00	0.82	5,10	25	130	0.75	400	5,10	WHT
BWNL002417151R0□00	1	5,10	15	115	0.8	350	5,10	BLK
BWNL002417151R2□00	1.2	5,10	15	95	0.9	325	5,10	BRN
BWNL002417151R5□00	1.5	5,10	15	85	1.05	300	5,10	RED
BWNL002417151R8□00	1.8	5,10	15	80	1.2	270	5,10	ORN
BWNL002417152R2□00	2.2	5,10	15	75	1.4	250	5,10	YEL
BWNL002417152R7□00	2.7	5,10	15	70	1.6	230	5,10	GRN
BWNL002417153R3□00	3.3	5,10	15	60	1.8	210	5,10	BLU
BWNL002417153R9□00	3.9	5,10	15	55	2	190	5,10	VIO
BWNL002417154R7□00	4.7	5,10	15	45	2.4	170	5,10	GRY
BWNL002417155R6□00	5.6	5,10	15	40	2.7	150	5,10	WHT
BWNL002417156R8□00	6.8	5,10	15	36	3.2	140	5,10	BLK
BWNL002417158R2□00	8.2	5,10	15	33	3.6	120	5,10	BRN
BWNL00241715100□00	10	5,10	15	30	4.5	110	5,10	RED
BWNL00241715120□00	12	5,10	15	25	5.7	105	5,10	ORN

NOTE: □-tolerance J=±5% / K=±10% / M=±20%

1. Operating temperature range - 2 5 °C ~ 1 0 5 °C (Including self - temperature rise)

2. IDC: Applied the current to coils, the inductance shall be less than 10% initial value.

3. L/Q Test OSC@200mV

BWNL00241715 Series Specification

Part No.	Inductance (uH)	Test Freq. (MHz)	Q Min.	SRF (MHZ)Min.	RDC (Ω)Max.	IDC (mA)	Tolerance (±%)	Color Code 1st
BWNL00241715150□00	15	5,10	15	23	6.5	90	5,10	YEL
BWNL00241715180□00	18	5,10	15	21	7	85	5,10	GRN
BWNL00241715220□00	22	5,10	15	20	8	78	5,10	BLU
BWNL00241715270□00	27	5,10	15	18	9	75	5,10	VIO
BWNL00241715330□00	33	5,10	15	17	10	70	5,10	GRY

NOTE: □-tolerance J=±5% / K=±10% / M=±20%

1. Operating temperature range - 25 °C ~ 105 °C (Including self - temperature rise)

2. IDC: Applied the current to coils, the inductance shall be less than 10% initial value.

3. L/Q Test OSC@200mV

BWNL00241715 Series Specification

8 BWNL00241715 Series

8.1 Construction:

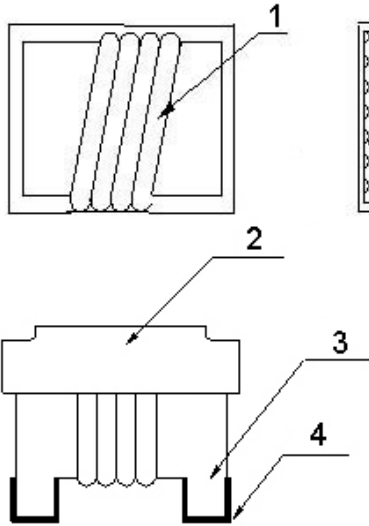

8.2 Material List:

NO	PART	MATERIAL
1	WIRE	COPPER 180
2	EPOXY	UV GLUE
3	CORE	FERRITE
4	TERMINAL	Ag/Cu/Ni/Sn

BWNL00241715 Series Specification

9 Reliability Of Ferrite Wire Wound Chip Inductor/FERRITE SERIES

1-1.Environmental Performance

No	Item	Specification	Test Method		
1-1-1	Temperature Cycle	Appearance: No Damage Inductance: within $\pm 10\%$ of initial value Q change: within $\pm 30\%$ of initial value	One cycle:		
			Step	Temperature ($^{\circ}\text{C}$)	Time (min)
			1	-40 ± 3	30
			2	25 ± 2	3
			3	105 ± 3	30
			4	25 ± 2	3
			Total: 5 cycles		
1-1-2	High Temperature Resistance		Measured After Exposure in The Room Condition For 1hrs		
			Temperature: $105\pm 3^{\circ}\text{C}$		
			Time: 1000Hrs		
			Measured After Exposure In The Room Condition For 1Hrs		
1-1-3	Low Temperature Resistance		Temperature: $-40\pm 3^{\circ}\text{C}$		
			Time: 1000Hrs		
			Measured After Exposure In The Room Condition For 1Hrs		
1-1-4	Humidity Load Life	There should be no evidence of short or open circle	Temperature: $40\pm 2^{\circ}\text{C}$		
			Relative Humidity: 90~95%		
			Load: Allowed DC Current		
			Time: 96Hrs		

1-2.Mechanical Performance

No	Item	Specification	Test Method
1-2-1	Resistance TO Soldering Heat	Appearance: No Damage	1. The device should be reflow soldered on PCB (peak $260^{\circ}\text{C} \pm 5^{\circ}\text{C}$ for 10 seconds) 2. Solder Composition: Sn/Ag3.0/Cu0.5 3. Test time: 6 minutes
1-2-2	Solder ability	The electrodes shall be at least 95% covered with new solder coating	1. Pre-Heating: 150°C , 1min. 2. Solder Composition: Sn/Ag3.0/Cu0.5 3. Solder Temperature: $245\pm 5^{\circ}\text{C}$. 4. Immersion Time: 4 ± 1 sec.
1-2-3	Component Adhesion (Push Test)	2 Lbs. For 2520 Size 4 Lbs. For 3225 Size	The device should be reflow soldered ($245\pm 5^{\circ}\text{C}$ For 10 seconds) to a tinned copper substrate. A force gauge should be applied to the side of the component. The device must withstand a minimum force of 1or2or4 pounds without a failure of the termination attached to component

BWNL00241715 Series Specification

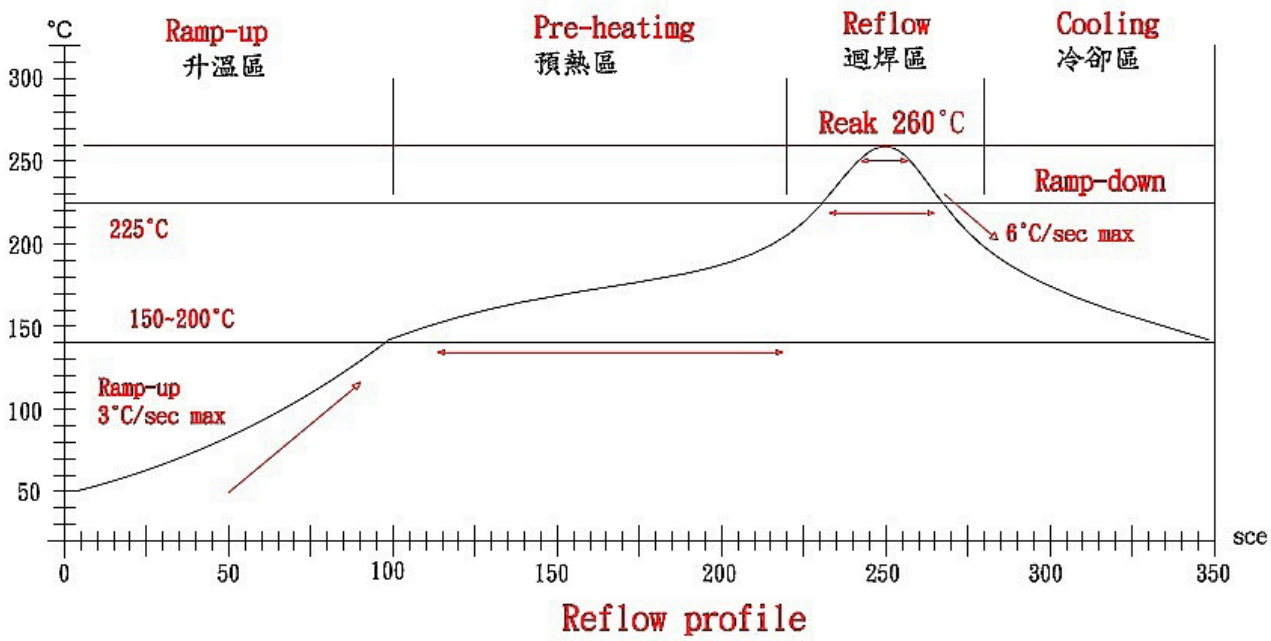

Lead-Free(LF)標準溫度分析範圍

Refer to J-STD-020C

管制項目 Item.	升温區 Ramp-up	預熱區 Pre-heating	迴焊區 Reflow	Peak Temp	冷卻區 Cooling
溫度範圍 Temp.scope	R.T ~ 150°C	150°C ~ 200°C	Above 217°C	260±5°C	Peak Temp.~150°C
標準時間 Time spec.	-	60 ~ 180 sec	60 ~ 150 sec	20 ~ 40 sec	-
實際時間 Time result	-	75 ~ 100 sec	90 ~ 120 sec	20 ~ 35 sec	-

NOTE :

1. Re-flow possible times : within 2 times
2. Nitrogen adopted is recommended while in re-flow
3. Products can only be soldered with reflow

BWNL00241715 Series Specification

10 Packaging:

10.1 Packaging -Cover Tape

The force for tearing off cover tape is 10 to 100 grams in the arrow direction.

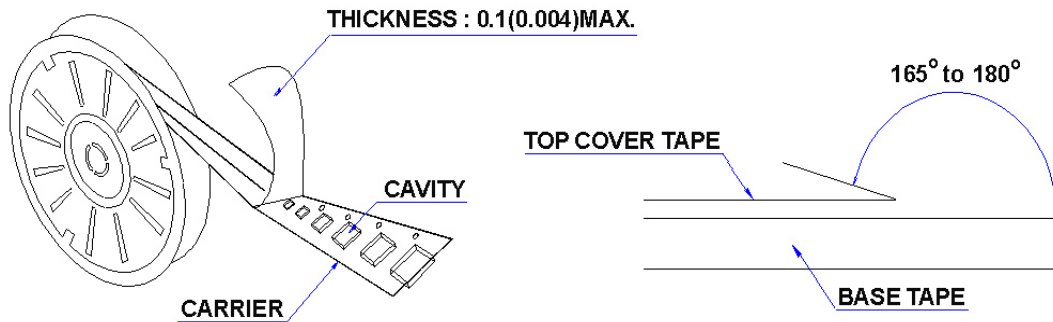

10.2 Packaging Quantity

TYPE	PCS/REEL
241715	2000

10.3 Reel Dimensions

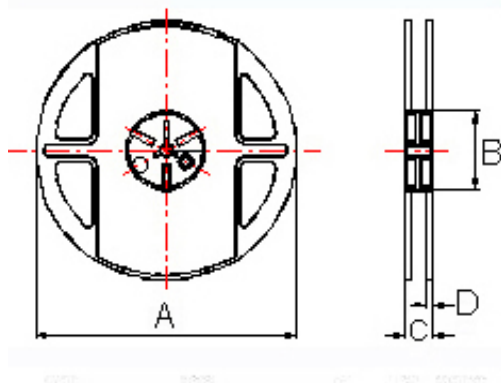

TYPE	A	B	C	D
241715	178±1	60±0.5	12±0.5	1.5±0.5

BWNC00292522 Series Specification

10 Packaging:

10.4 Tape Dimensions in mm

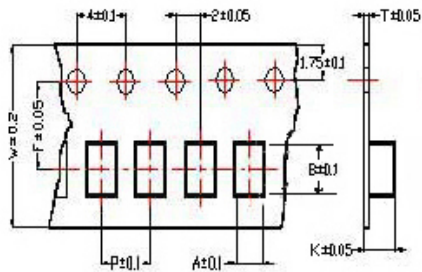

Tape Material

Carrier tape : Polycarbonate
Cover tape : Polyethylene

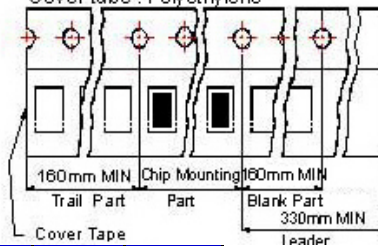

TYPE	A	B	T	W	P	F	K
241715	1.85	2.45	0.2	8	4	3.5	1.45

11 Recommended Land Pattern:

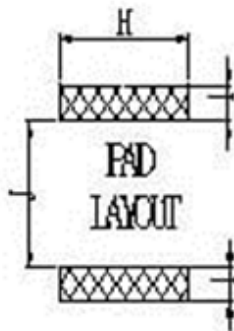

Dimensions in mm

TYPE	H(In/mm)	I(In/mm)	J(In/mm)
241715	0.07/1.78	0.04/1.02	0.06/0.76

12 Note:

- Please make sure that your product has been evaluated and confirmed against your specifications when our product is mounted to your product.
- Do not knock nor drop.
- All the items and parameters in this product specification have been prescribed on the premise that our product is used for the purpose, under the condition and in the environment agreed upon between you and us. You are requested not to use our product deviating from such agreement.
- The storage period is less than 12 months. Be sure to follow the storage conditions (Temperature: 5 to 40°C, Humidity: 10 to 75% RH or less).
If the storage period elapses, the soldering of the terminal electrodes may deteriorate.
- Do not use or store in locations where there are conditions such as gas corrosion (salt, acid, alkali, etc.).
- The moisture sensitivity level (MSL) of products is classified as level 1.

BWNL00241715 Series Specification

12 Graph:

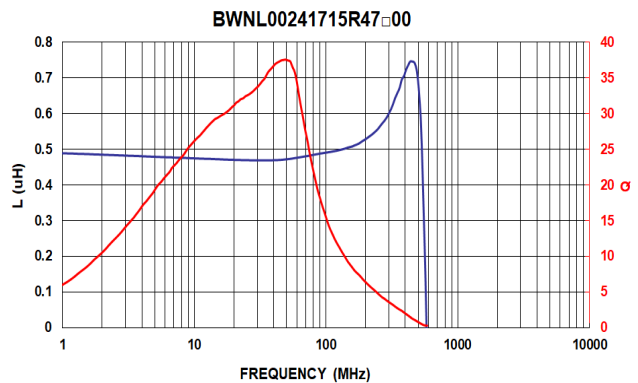
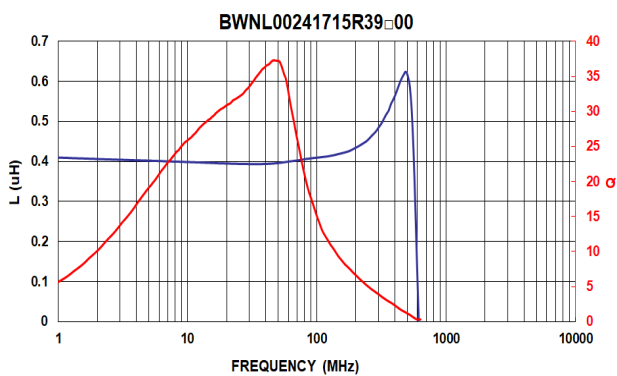
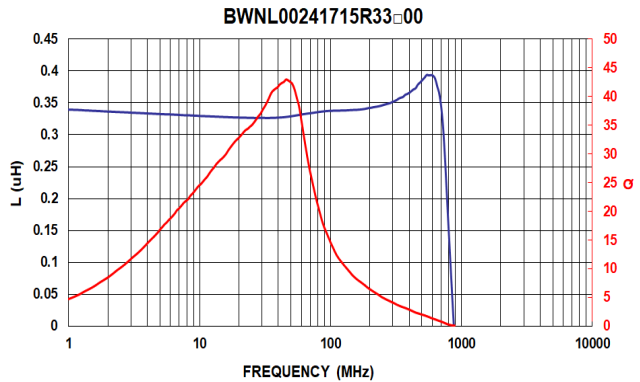
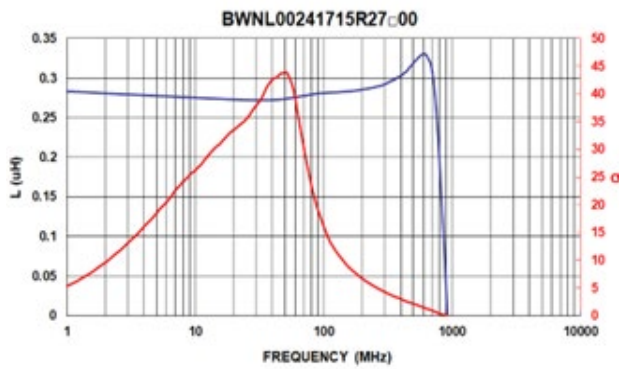
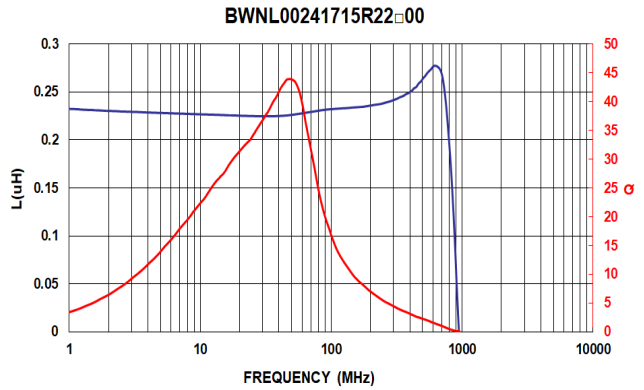
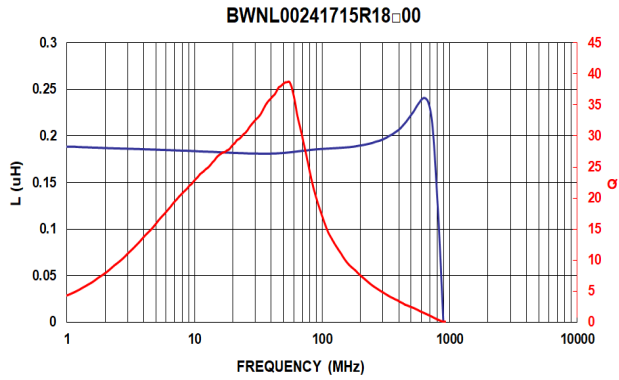
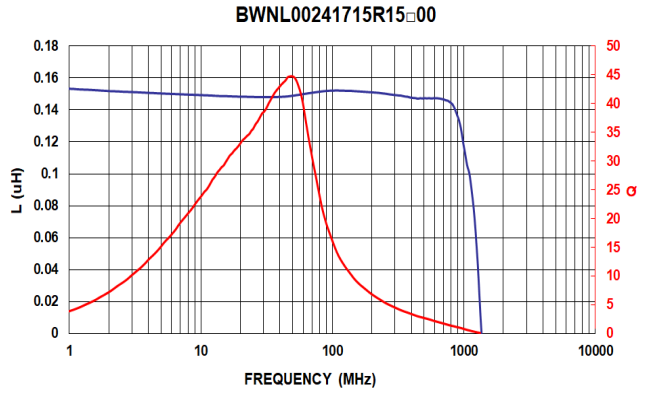
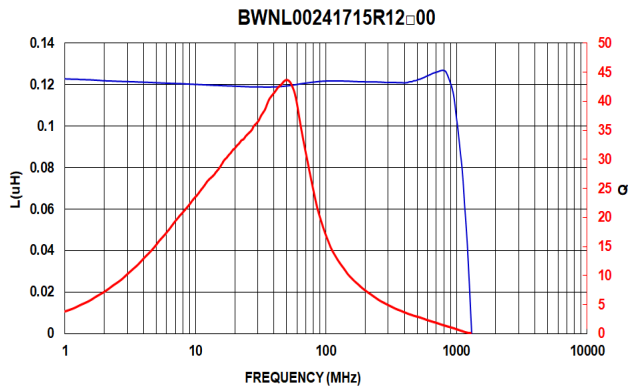

BWNL00241715 Series Specification

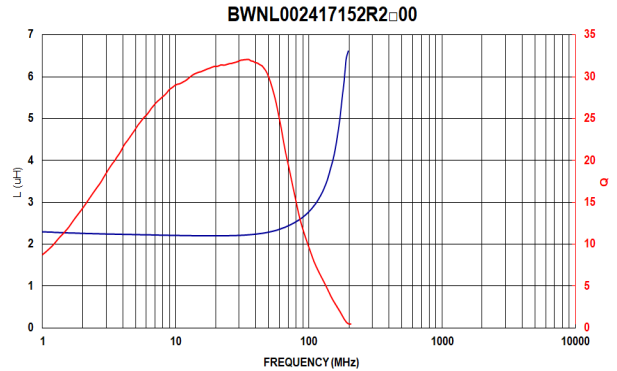
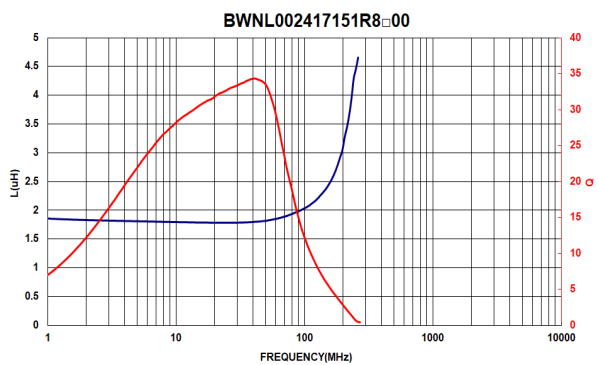
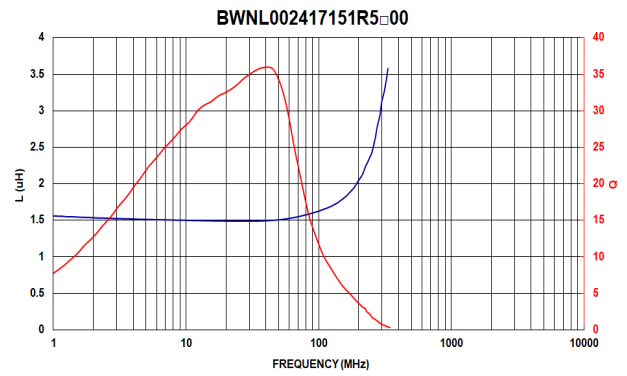
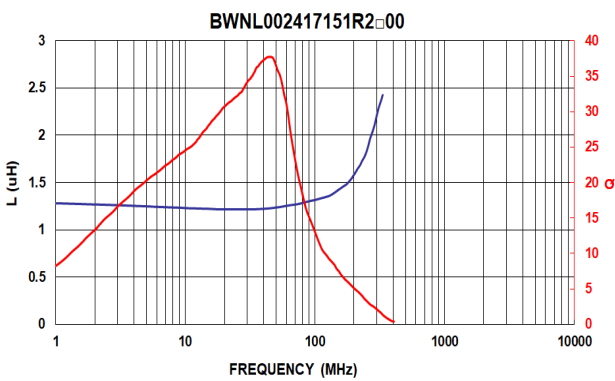
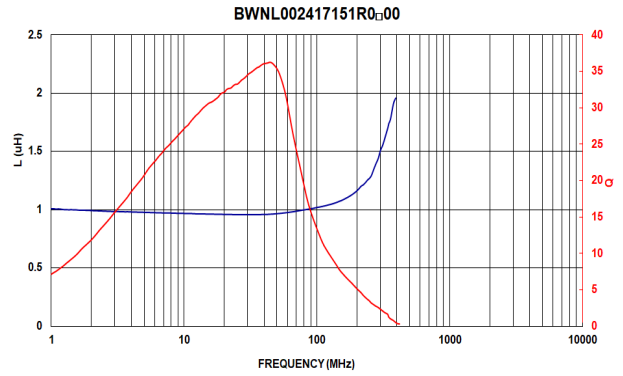
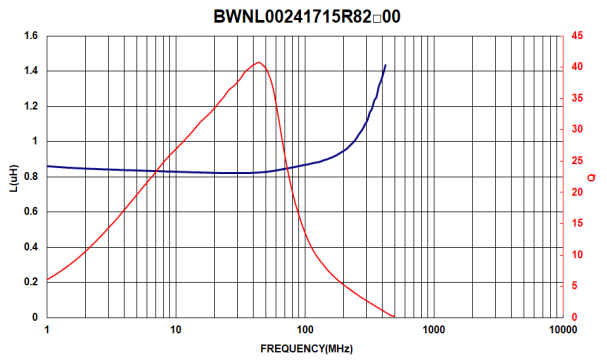
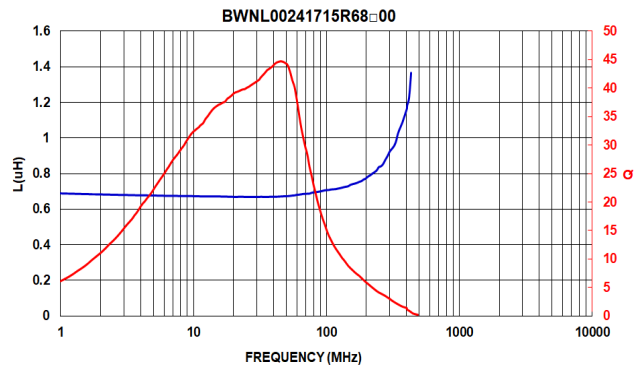
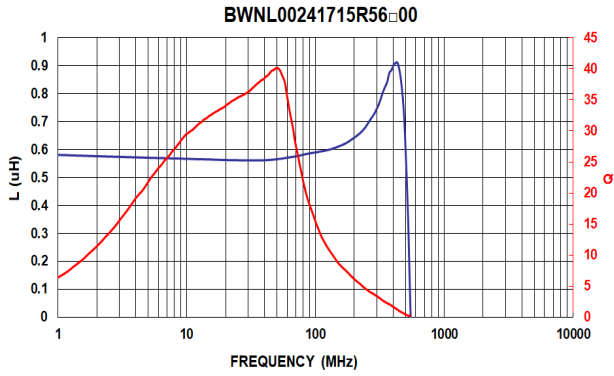

BWNL00241715 Series Specification

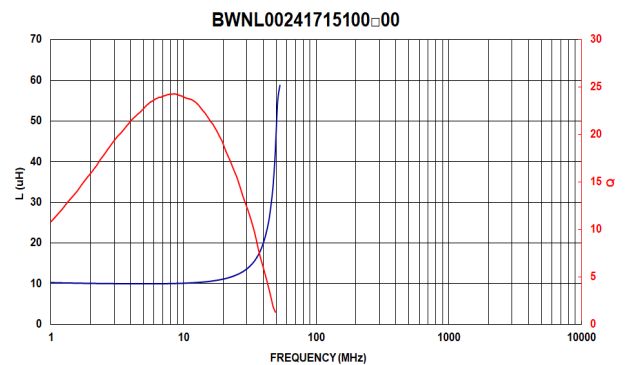
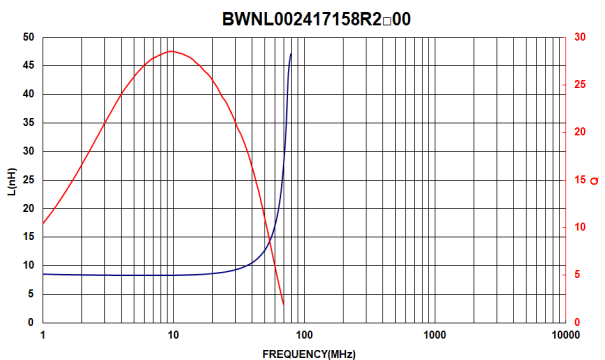
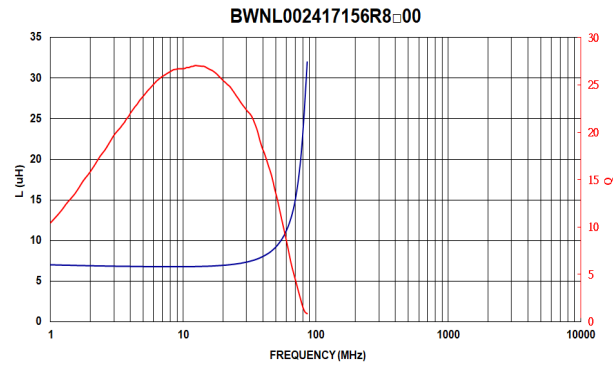
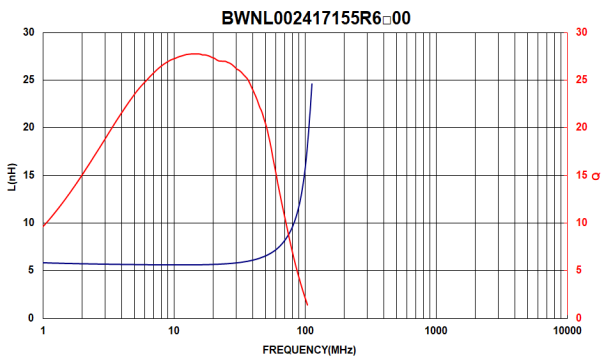
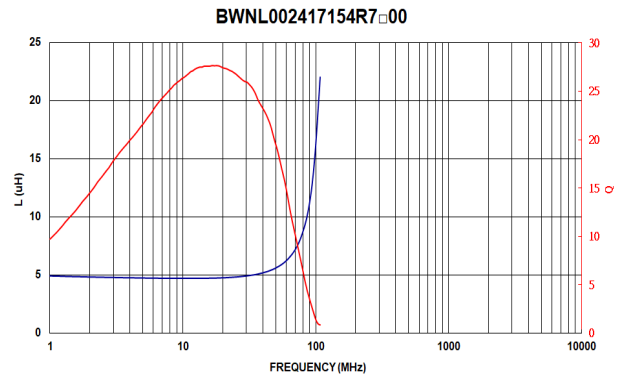
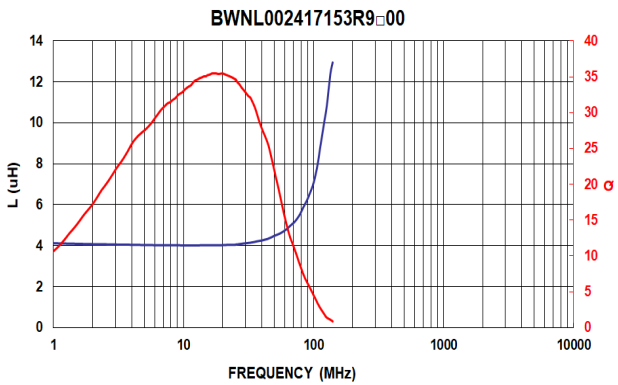
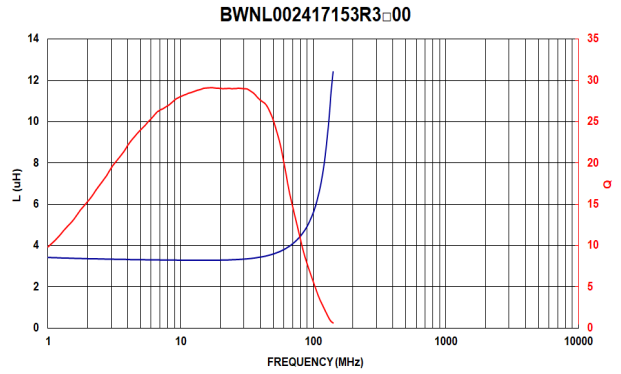
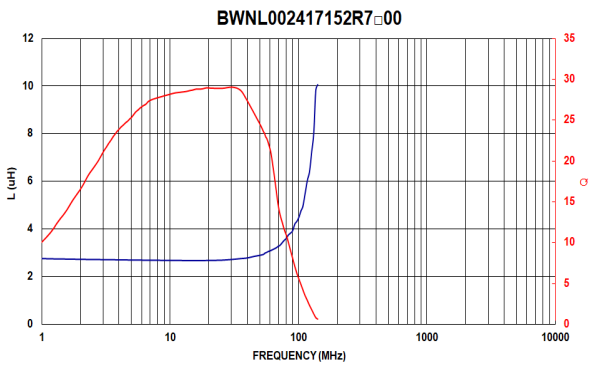

BWNL00241715 Series Specification

