

RF Inductor



BWCM Series



Overview

Wire-wound RF inductors are electronic components designed to store energy in a magnetic field when electrical current passes through them. They are constructed by winding a conductive wire (usually copper or gold-plated) around a core material such as air, ceramic, or ferrite.

This configuration allows them to provide high inductance values with minimal power loss, especially at high frequencies.

Benefits

1. High Q-Factor (Quality Factor)
2. Ceramic body and wire wound construction provide high SRFs
3. Low DC resistance design
4. High Current Handling
5. Can maintain excellent thermal stability at different temperatures

Applications

1. Industrial and Medical Equipmen: RFID systems and medical imaging equipment.
2. Data Centers
3. Networking
4. Base Station
5. Consumer Electronics
6. Security system

Product Information

Series	Size Code (JIS/EIA)	Inductance (nH)
BWCM	0603/0201 1005/0402 1608/0603	1 ~ 470



BWCM00110705 Series Specification

1 Scope: This specification applies to Wire Wound Ceramic Chip Inductors

2 Part Numbering:

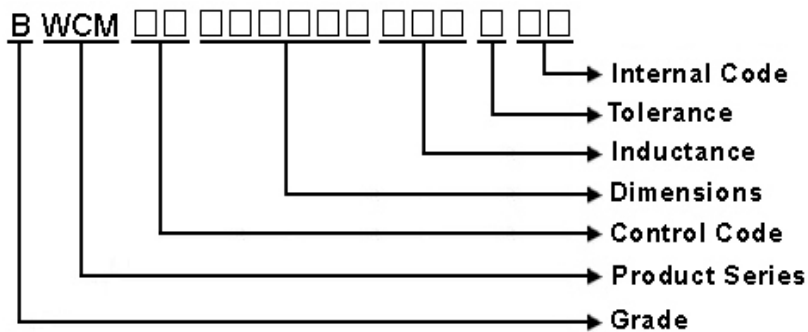

3 Rating:

Operating Temperature: - 40°C ~ 125°C
(Including self - temperature rise)

Storage Temperature: - 40°C ~ 125°C
(The storage temperature range is for after the assembly)

4 Marking:

No Marking

5 Standard Testing Condition

	Unless otherwise specified	In case of doubt
Temperature	Ordinary Temperature(15 to 35°C)	20 to 30°C
Humidity	Ordinary Humidity(25 to 85% RH)	50 to 80 %RH

BWCM00110705 Series Specification

6 Configuration and Dimensions and Unit Weight:

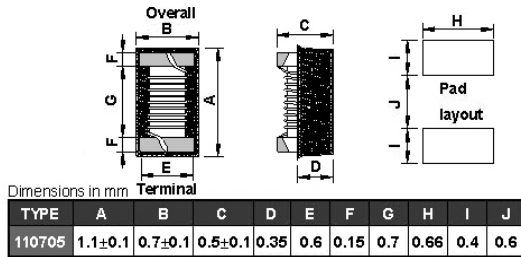

Net Weight (grms)

SIZE CODE	Net Weight (grms)
110705	0.0008 (typ.)

7 Electrical Characteristics:

Part No.	Inductance (nH)	L/Q Test Freq. (MHz)	Q Typ.	SRF (MHz)Min.	RDC (Ω)Max.	I _{rms} (mA)Typ.	Tolerance
BWCM001107051N3□L8	1.3	100/250	20	18000	0.017	1200	B,C,D
BWCM001107051N4□L8	1.4	100/250	25	18000	0.019	1100	B,C,D,G
BWCM001107052N2□L8	2.2	100/250	30	15500	0.022	2530	B,C,D,G
BWCM001107052N4□L8	2.4	100/250	30	15500	0.022	2530	B,C,D,G
BWCM001107053N2□L8	3.2	100/250	30	14000	0.03	2000	B,C,D,G
BWCM001107053N3□L8	3.3	100/250	30	14000	0.03	2000	B
BWCM001107053N4□L8	3.4	100/250	30	10000	0.03	1950	B,C,D,G
BWCM001107053N5□L8	3.5	100/250	30	10000	0.03	1950	B,C,D,G
BWCM001107053N6□L8	3.6	100/250	30	10000	0.03	1950	B,C,D,G
BWCM001107055N0□L8	5	100/250	32	10000	0.04	1770	B,C,D,G
BWCM001107055N1□L8	5.1	100/250	35	8000	0.04	1770	B,C,D,G
BWCM001107055N2□L8	5.2	100/250	35	8000	0.04	1770	B,C,D,G
BWCM001107055N3□L8	5.3	100/250	35	8000	0.04	1770	B,C,D,G
BWCM001107055N4□L8	5.4	100/250	35	8000	0.04	1770	B,C,D,G
BWCM001107055N5□L8	5.5	100/250	35	8000	0.04	1770	B,C,D,G
BWCM001107055N6□L8	5.6	100/250	35	8000	0.04	1770	B,C,D,G
BWCM001107055N7□L8	5.7	100/250	30	8000	0.04	1770	B,C,D,G
BWCM001107057N2□L8	7.2	100/250	32	7000	0.05	1700	G,J
BWCM001107057N3GL8	7.3	100/250	32	7000	0.05	1700	G,J
BWCM001107057N4□L8	7.4	100/250	30	7000	0.05	1700	G,J
BWCM001107057N5□L8	7.5	100/250	35	7000	0.05	1700	G,J
BWCM001107057N6□L8	7.6	100/250	30	7000	0.05	1700	G,J
BWCM001107057N7□L8	7.7	100/250	30	7000	0.05	1700	G,J
BWCM001107059N2□L8	9.2	100/250	32	6000	0.081	1400	G,J

NOTE: □-tolerance B=±0.1nH / C=±0.2nH / D=±0.5nH / G=±2% / J=±5%

1. Operating temperature range - 4 0 °C ~ 1 2 5 °C (Including self - temperature rise)
2. I_{rms} for a 15°C temperature rise from 25°C ambient.
3. L/Q Test OSC @200mV.
4. Inductance would be correct Chilisin standard piece.
5. Offset value : -0.556nH
6. weight: 0.0008(typ.)

BWCM00110705 Series Specification

Part No.	Inductance (nH)	L/Q Test Freq. (MHz)	Q Typ.	SRF (MHz)Min.	RDC (Ω)Max.	Irms (mA)Typ.	Tolerance
BWCM001107059N3 \square L8	9.3	100/250	34	6000	0.081	1400	G,J
BWCM001107059N4 \square L8	9.4	100/250	33	6000	0.081	1400	G,J
BWCM001107059N5 \square L8	9.5	100/250	32	6000	0.081	1400	G,J
BWCM001107059N6 \square L8	9.6	100/250	33	6000	0.081	1400	G,J
BWCM001107059N7 \square L8	9.7	100/250	33	6000	0.081	1400	G,J
BWCM001107059N8 \square L8	9.8	100/250	34	6000	0.081	1400	G,J
BWCM001107059N9 \square L8	9.9	100/250	32	6000	0.081	1400	G,J
BWCM0011070510N \square L8	10	100/250	31	6000	0.081	1400	G,J
BWCM0011070512N \square L8	12	100/250	30	5200	0.093	1240	G,J
BWCM0011070513N \square L8	13	100/250	30	5200	0.093	1240	G,J
BWCM0011070516N \square L8	16	100/250	31	5000	0.126	1000	G,J
BWCM0011070521NGL8	21	100/250	30	4500	0.202	780	G,J
BWCM0011070522N \square L8	22	100/250	30	4500	0.202	780	G,J
BWCM0011070530N \square L8	30	100/250	30	3800	0.309	660	G,J
BWCM0011070536N \square L8	36	100/250	30	3500	0.431	540	G,J
BWCM0011070543N \square L8	43	100/250	30	3400	0.516	515	G,J

NOTE: \square -tolerance B= \pm 0.1nH / C= \pm 0.2nH / D= \pm 0.5nH / G= \pm 2% / J= \pm 5%

1. Operating temperature range - 4 0 °C ~ 1 2 5 °C (Including self - temperature rise)
2. Irms for a 15°C temperature rise from 25°C ambient.
3. L/Q Test OSC @200mV.
4. Inductance would be correct Chilisin standard piece.
5. Offset value : -0.556nH
6. weight: 0.0008(typ.)

BWCM00110705 Series Specification

8 BWCM00110705 Series

8.1 Construction:

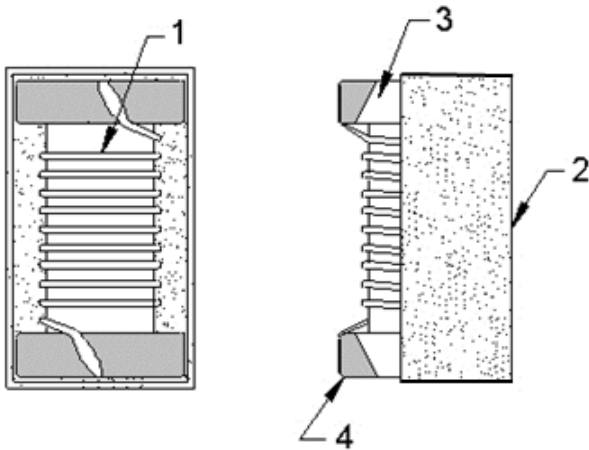

8.2 Material List:

NO	PART	MATERIAL
1	WIRE	Grade 180
2	EPOXY	UV GLUE
3	CORE	CERAMIC
4	TERMINAL	Ag/Ni/Sn

BWCM00110705 Series Specification

9 Reliability Of Ceramic Wire Wound Chip Inductor/CERAMIC SERIES

1-1.Environmental Performance

No	Item	Specification	Test Method		
1-1-1	Temperature Cycle	Appearance: No Damage Inductance: within $\pm 10\%$ of initial value Q change: within $\pm 30\%$ of initial value	One cycle:		
			Step	Temperature ($^{\circ}\text{C}$)	Time (min)
			1	-40 \pm 3	30
			2	25 \pm 2	15
			3	125 \pm 3	30
4	25 \pm 2	15			
			Total: 5 cycles Measured After Exposure in The Room Condition For 1hrs		
1-1-2	Humidity Resistance		Temperature: 40 \pm 2 $^{\circ}\text{C}$ Relative Humidity: 90 ~ 95% Time: 96hrs Measured After Exposure In The Room Condition For 1hrs		
1-1-3	High Temperature Resistance		Temperature: 125 \pm 3 $^{\circ}\text{C}$ Time: 1000Hrs Measured After Exposure In The Room Condition For 1Hrs		
1-1-4	Low Temperature Resistance		Temperature: -40 \pm 3 $^{\circ}\text{C}$ Time: 1000Hrs Measured After Exposure In The Room Condition For 1Hrs		
1-1-5	Humidity Load Life	There should be no evidence of short or open circle	Temperature: 40 \pm 2 $^{\circ}\text{C}$ Relative Humidity: 90~95% Load: Allowed DC Current Time: 1000Hrs		

1-2.Mechanical Performance

No	Item	Specification	Test Method
1-2-1	Vibration Test (Low Frequency)	1.Appearance: No Damage 2.Inductance: within $\pm 10\%$ of initial value 3.Q change: within $\pm 30\%$ of initial value	1. Test device shall be soldered on the substrate. 2. Oscillation frequency: 10 to 55 to 10Hz for 1min. 3. Amplitude: 1.5mm 4. Time: 2hrs for each axis(X, Y & Z),total 6hrs
1-2-2	Resistance TO Soldering Heat	Appearance: No Damage	1. The device should be reflow soldered on PCB (peak 260 $^{\circ}\text{C}$ \pm 5 $^{\circ}\text{C}$ for 10 seconds) 2. Solder Composition: Sn/Ag3.0/Cu0.5 3. Test time: 6 minutes
1-2-3	Solder ability	The electrodes shall be at least 95% covered with new solder coating	1. Pre-Heating: 150 $^{\circ}\text{C}$, 1min. 2. Solder Composition: Sn/Ag3.0/Cu0.5 3. Solder Temperature: 245 \pm 5 $^{\circ}\text{C}$. 4. Immersion Time: 4 \pm 1 sec.
1-2-4	Component Adhesion (Push Test)	1 Lbs. For 0402 2 Lbs. For 0603 4 Lbs. For The Rest	The device should be reflow soldered (245 \pm 5 $^{\circ}\text{C}$ For 10 seconds) to a tinned copper substrate. A force gauge should be applied to the side of the component. The device must withstand a minimum force of 2 or 4 pounds without a failure of the termination attached to component

BWCM00110705 Series Specification

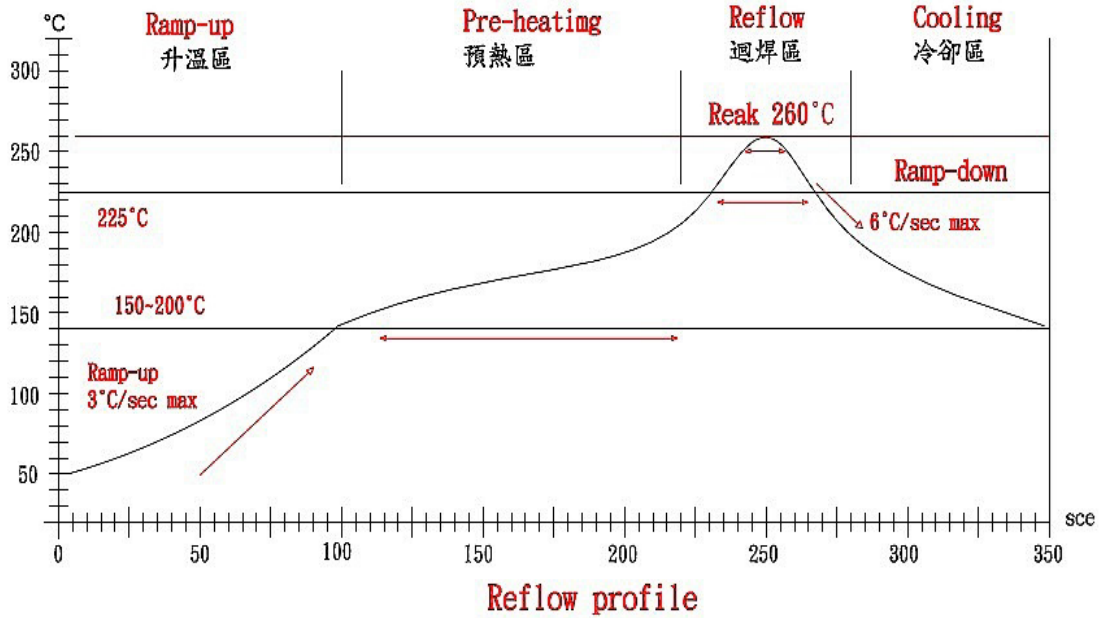

Lead-Free(LF)標準溫度分析範圍

Refer to J-STD-020C

管制項目 Item.	升温區 Ramp-up	預熱區 Pre-heating	迴焊區 Reflow	Peak Temp	冷卻區 Cooling
溫度範圍 Temp.scope	R.T ~ 150°C	150°C ~ 200°C	Above 217°C	260±5°C	Peak Temp.~150°C
標準時間 Time spec.	-	60 ~ 180 sec	60 ~ 150 sec	20 ~ 40 sec	-
實際時間 Time result	-	75 ~ 100 sec	90 ~ 120 sec	20 ~ 35 sec	-

NOTE:

- 1.Re-flow possible times : within 3 times
- 2.Nitrogen adopted is recommendes while in re-flow
- 3.Products can only be soldered with reflow

BWCM00110705 Series Specification

10 Packaging:

10.1 Packaging -Cover Tape

The force for tearing off cover tape is 10 to 100 grams in the arrow direction.

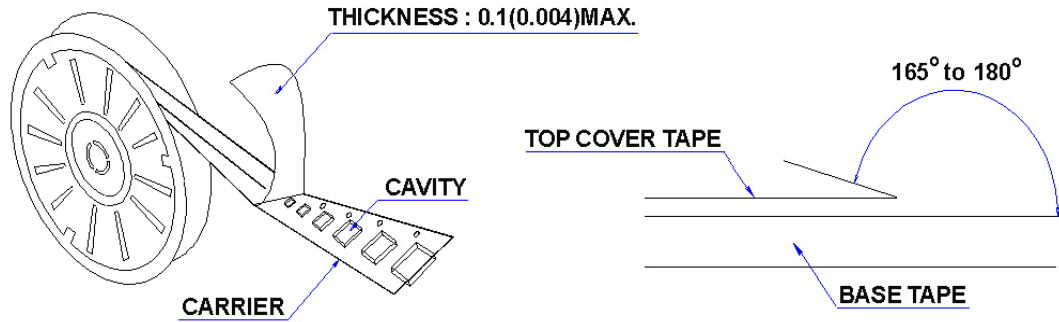

10.2 Packaging Quantity

TYPE	PCS/REEL
110705	4000

10.3 Reel Dimensions

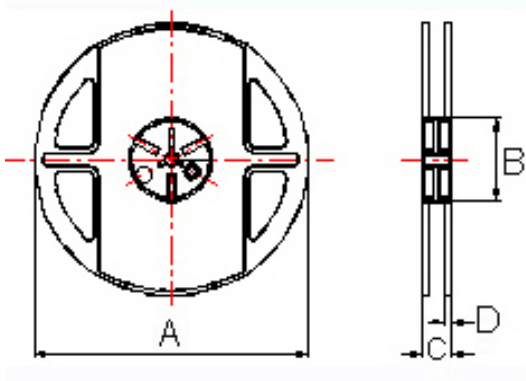

Dimensions in mm

TYPE	A	B	C	D
110705	178±1	60±0.5	12±0.5	1.5±0.5

BWCM00110705 Series Specification

10 Packaging:

10.4 Tape Dimensions in mm

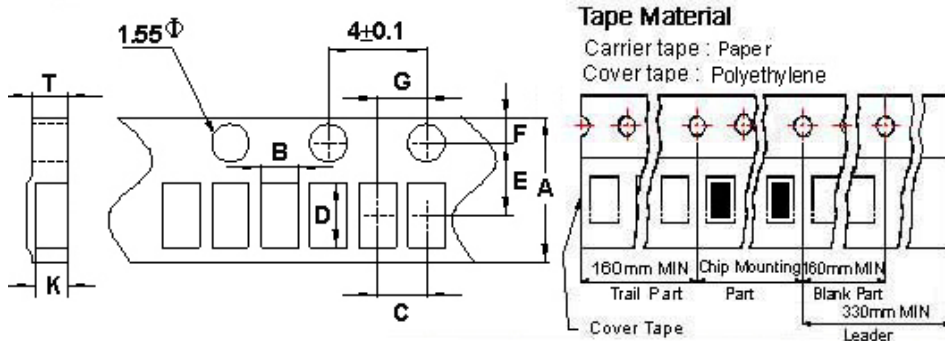

TYPE	A	B	C	D	E	F	G	T	K
110705	8.0	0.85	2	1.25	3.5	1.75	2	0.75	0.6

11 Recommended Land Pattern:

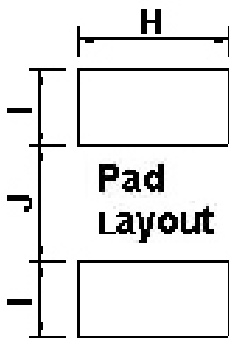

Dimensions in mm

TYPE	H(In/mm)	I(In/mm)	J(In/mm)
110705	0.026/0.66	0.016/0.40	0.024/0.60

12 Note:

- Please make sure that your product has been evaluated and confirmed against your specifications when our product is mounted to your product.
- Do not knock nor drop.
- All the items and parameters in this product specification have been prescribed on the premise that our product is used for the purpose, under the condition and in the environment agreed upon between you and us. You are requested not to use our product deviating from such agreement.
- The storage period is less than 12 months. Be sure to follow the storage conditions (Temperature: 5 to 40°C, Humidity: 10 to 75% RH or less).
If the storage period elapses, the soldering of the terminal electrodes may deteriorate.
- Do not use or store in locations where there are conditions such as gas corrosion (salt, acid, alkali, etc.).
- The moisture sensitivity level (MSL) of products is classified as level 1.

BWCM00110705 Series Specification

13 Graph:

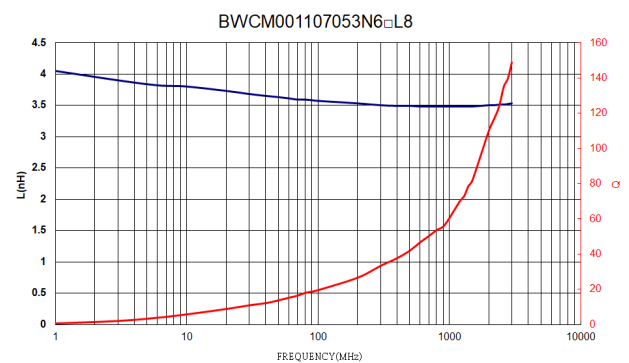
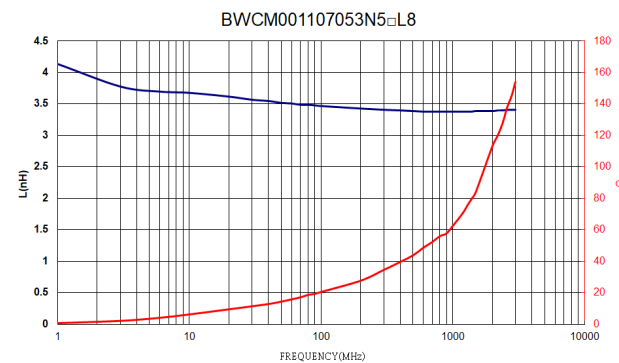
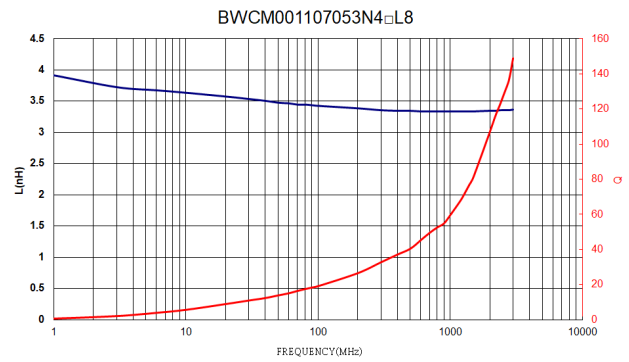
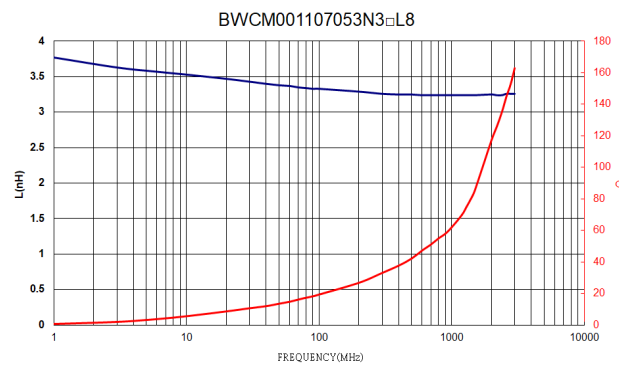
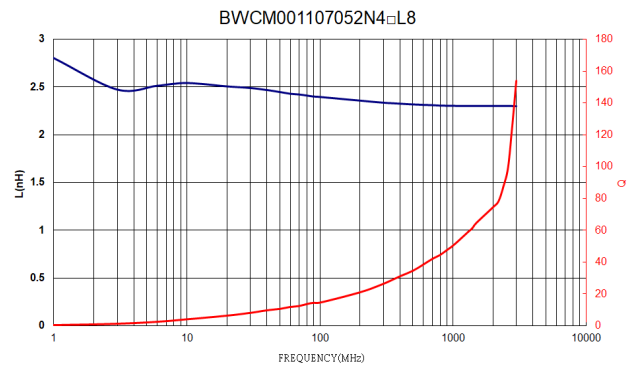
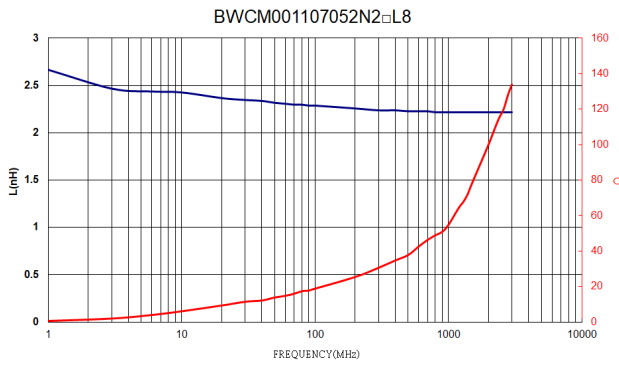
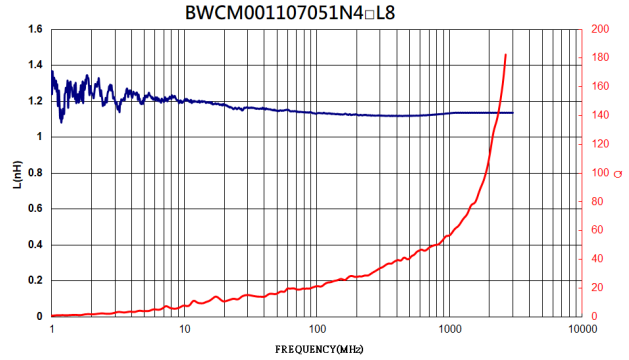
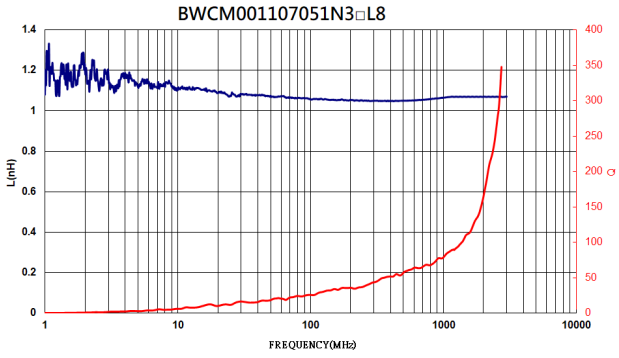

BWCM00110705 Series Specification

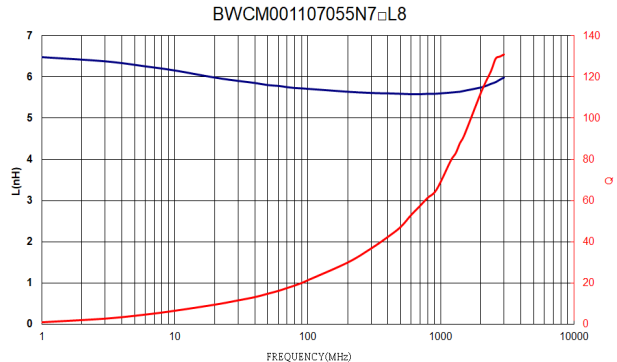
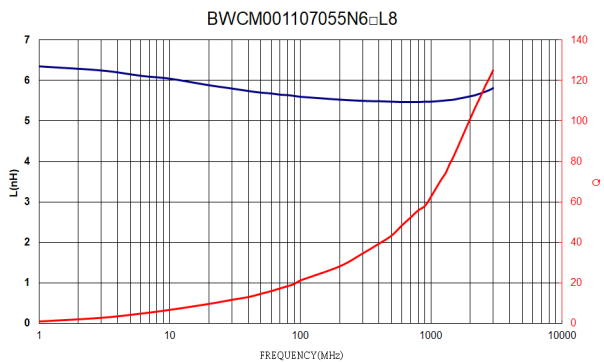
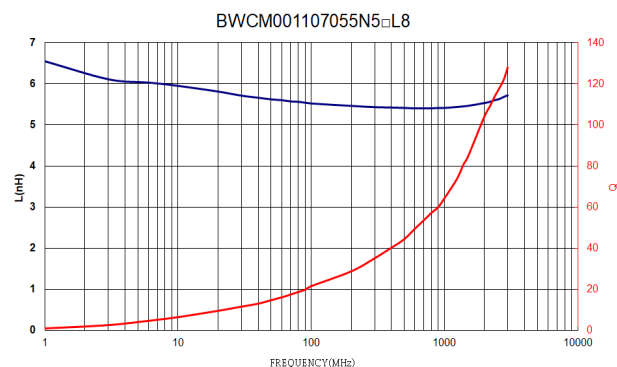
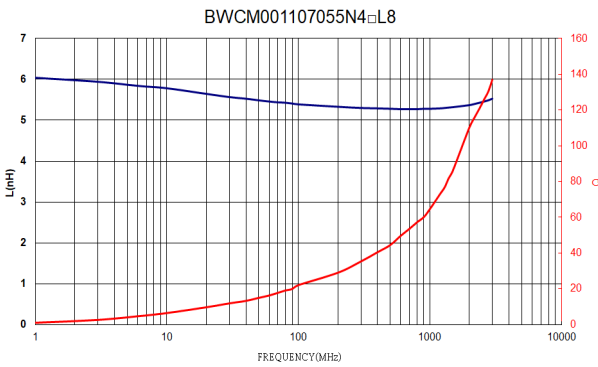
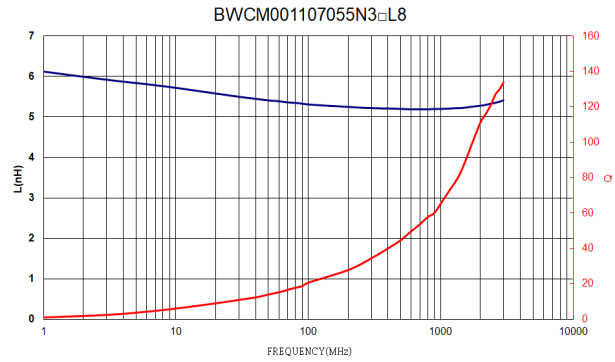
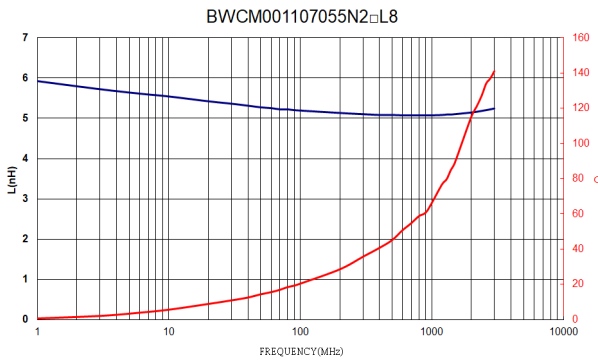
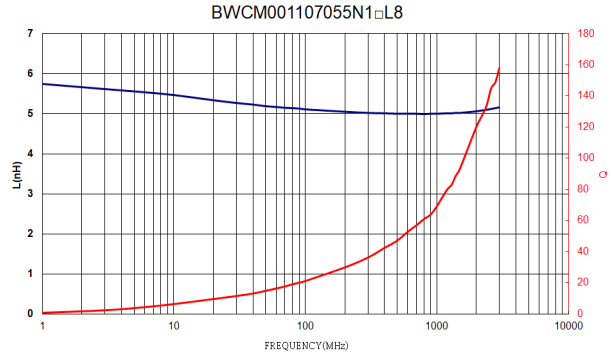
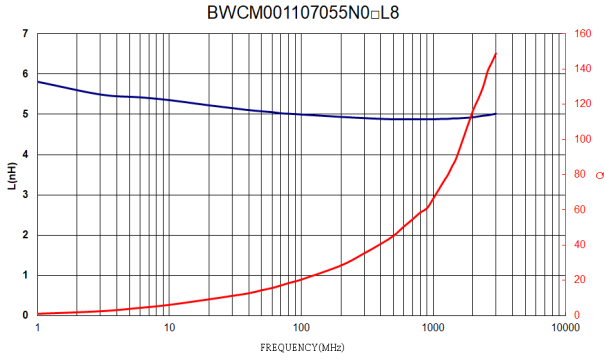

BWCM00110705 Series Specification

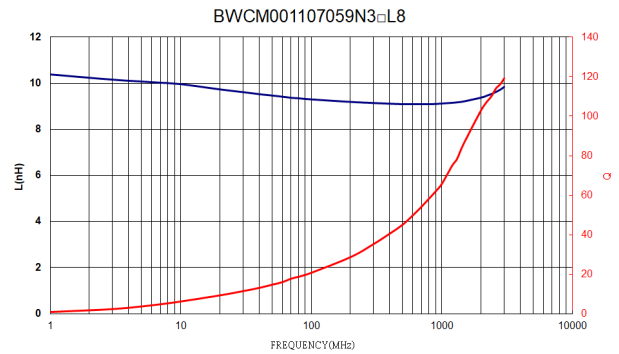
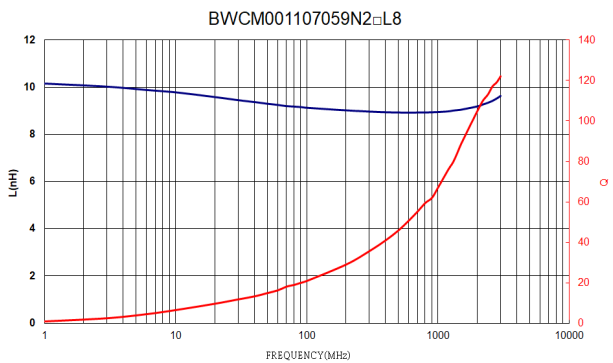
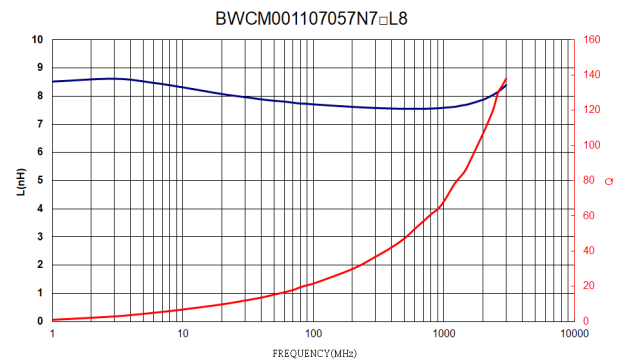
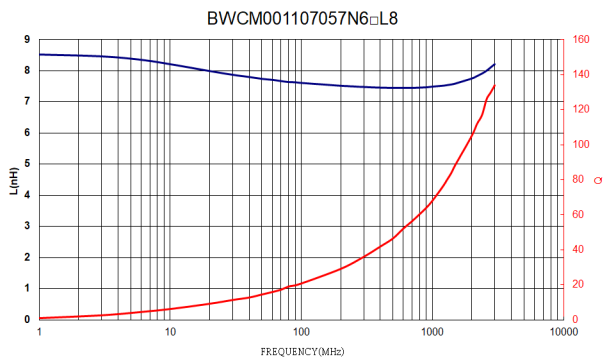
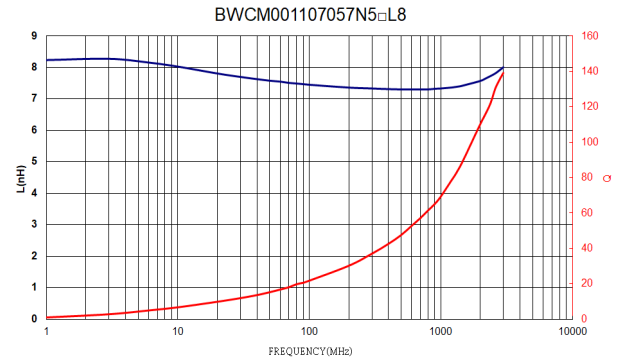
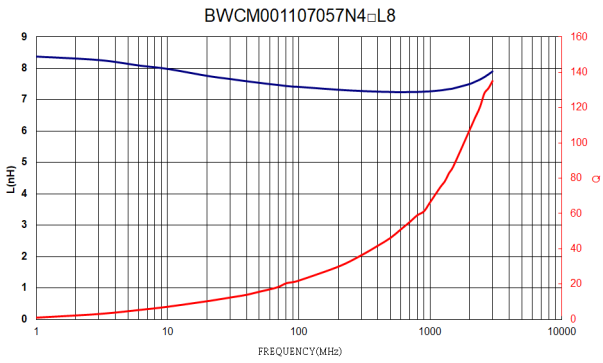
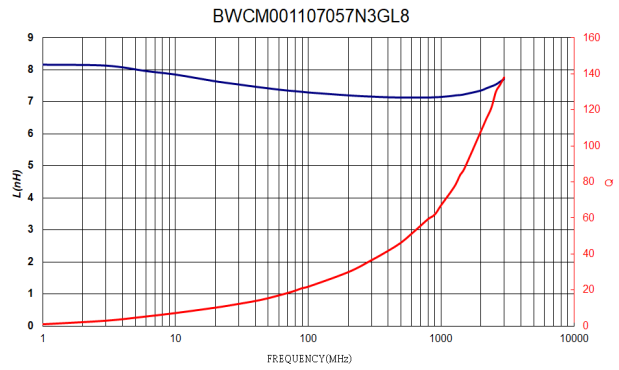
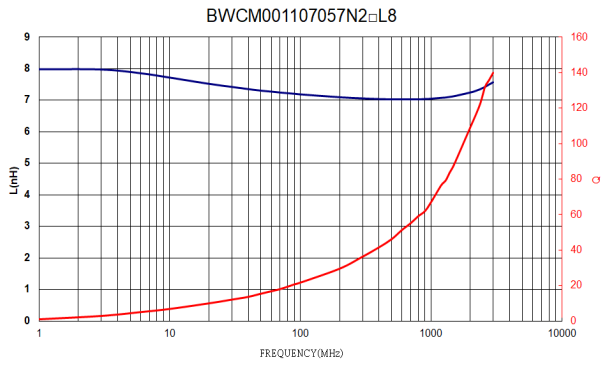

BWCM00110705 Series Specification

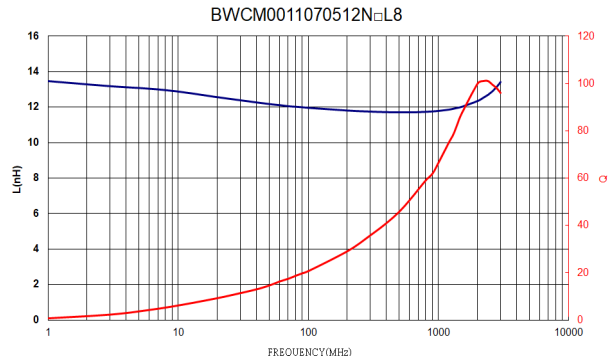
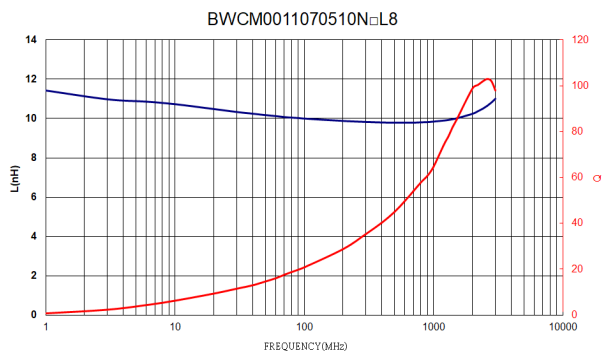
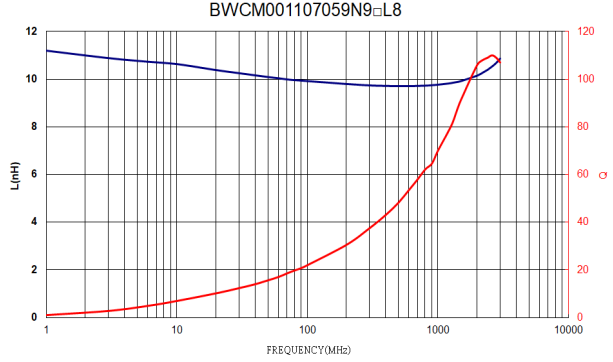
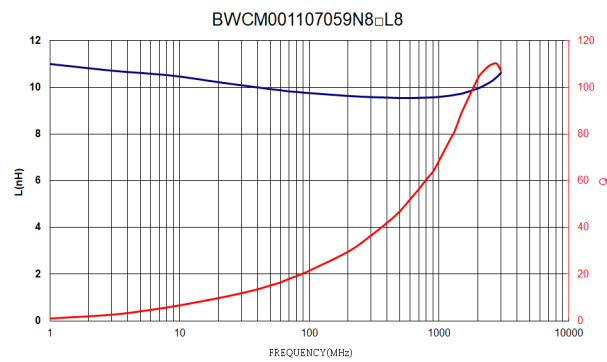
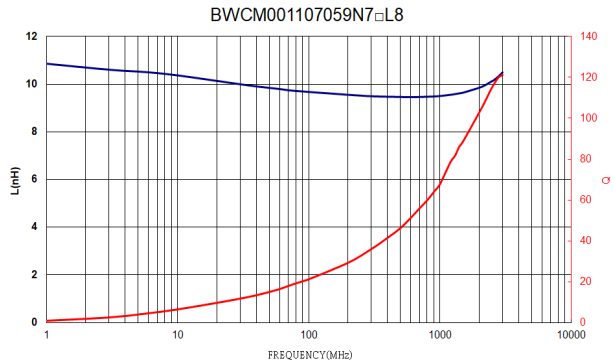
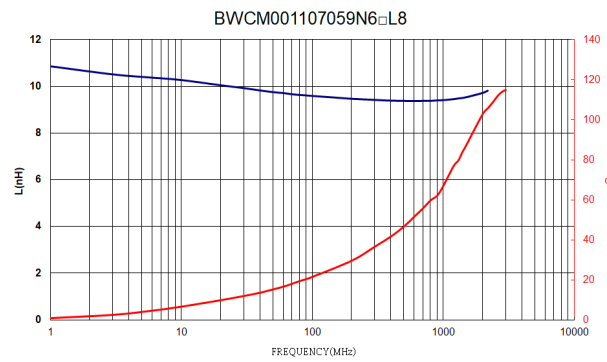
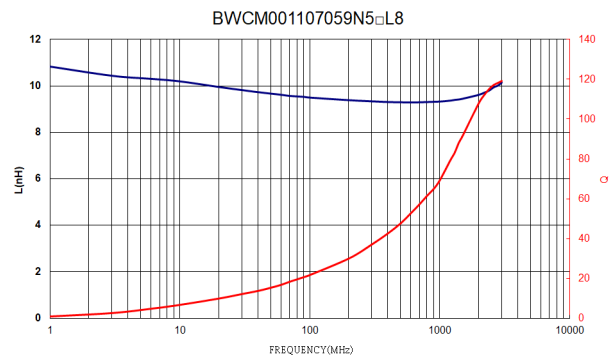
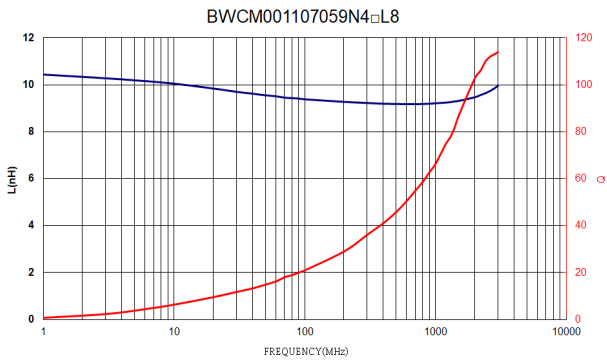

BWCM00110705 Series Specification

BWCM0011070513N□L8

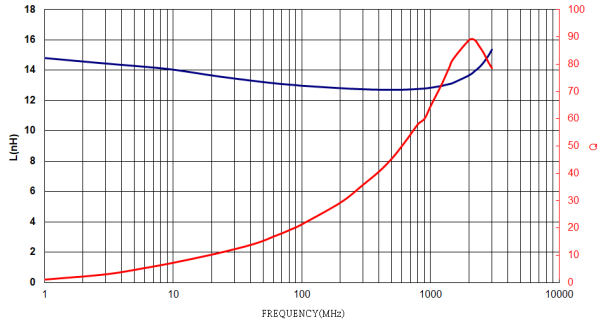

BWCM0011070516N□L8

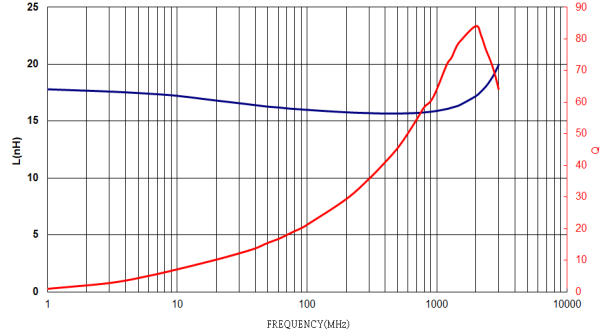

BWCM0011070522N□L8

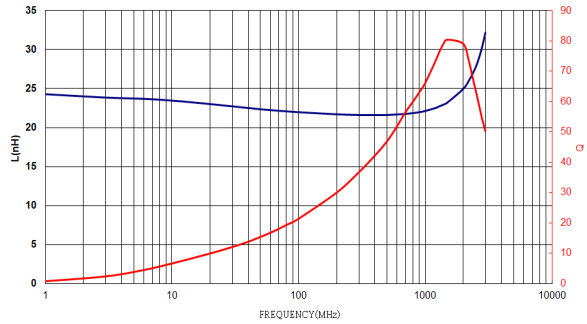

BWCM0011070530N□L8

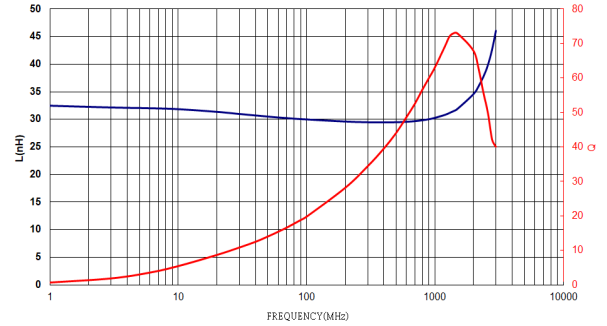

BWCM0011070536N□L8

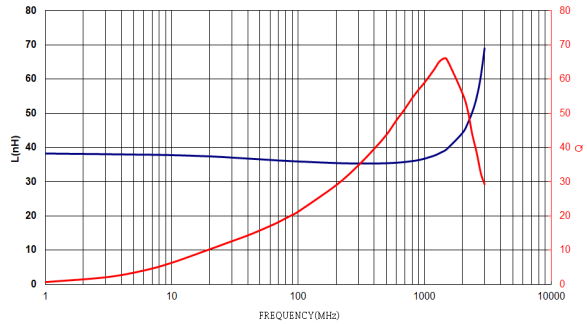

BWCM0011070543N□L8

