

# Power Inductor

## BPSC Series



### Overview

Power inductors are passive electronic components used in various circuits to store energy in a magnetic field when electrical current flows through them. They are critical in filtering, energy storage, and noise suppression in power electronic systems. They are designed to handle higher currents and are optimized for minimal power loss and thermal efficiency.

### Benefits

1. Ferrite SMD Shielded Type
2. No thermal aging

### Applications

1. AP Routers, STBs
2. LCD TVs and monitors
3. Game consoles
4. LED lightings
5. DC/DC converters

### Product Information

Series	L (mm)	W(mm)	T (mm)	Inductance (μH)
BPSC	3.2	3.2	1.55	0.47 ~ 3300
	3.2	3.2	2.0	
	4.0	4.0	1.2	
	4.0	4.0	1.8	
	4.0	4.0	3.0	
	4.7	4.7	2.0	
	4.7	4.7	3.0	
	4.7	4.7	4.0	
	5.7	5.7	2.0	
	5.7	5.7	3.0	
	6.7	6.7	3.0	
	7.3	7.3	3.4	
	7.0	7.0	4.0	
	7.3	7.3	4.5	
	8.3	8.3	4.5	
	10.3	10.5	3.1	
	10.3	10.5	4	
	10.3	10.5	5.1	
12.5	12.5	4.5		
12.5	12.5	6		
12.5	12.5	8		
12.0	12.0	10.0		



## BPSC00101151 Series Specification

**1 Scope:** This specification applies to SMD Shielded Power Inductors

**2 Part Numbering:**

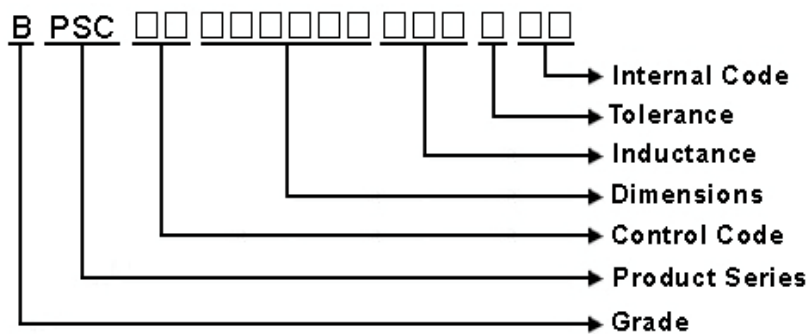

**3 Rating:**

Operating Temperature:  $-40^{\circ}\text{C} \sim +125^{\circ}\text{C}$  (Including self temp. rise)

Storage Temperature:  $-40^{\circ}\text{C} \sim +125^{\circ}\text{C}$  (For after the circuit board is mounted)

Storage Temperature: (on tape & reel):  $-20^{\circ}\text{C}$  to  $+40^{\circ}\text{C}$ ; 75% RH max.

**4 Marking:**

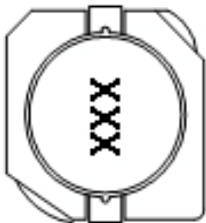

**Ex Marking: 100**

**Marking color : Black**

**5 Standard Testing Condition**

	Unless otherwise specified	In case of doubt
Temperature	Ordinary Temperature(15 to 35°C)	20 to 30°C
Humidity	Ordinary Humidity(25 to 85% RH)	50 to 80 %RH

## BPSC00101151 Series Specification

### 6 Configuration and Dimensions and Unit Weight:

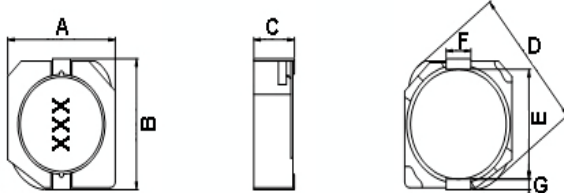

Dimensions in mm

TYPE	A	B	C	D	E	F	G
101151	10.3Max.	10.5Max.	5.1 Max.	13.5Max.	7.7	3.0	1.2

### Net Weight (grms)

SIZE CODE	Net Weight (grms)
101151	1.67(Typ.)

### 7 Electrical Characteristics:

Part No.	Inductance (uH)	Test Freq.	RDC (Ω)Max.	Isat(A) Max(Typ)	Irms (A)Typ.	Tolerance	Marking
BPSC00101151R80□00	0.8	100 kHz,1 V	0.0062	10.8(13.5)	7.8	T	R80
BPSC001011511R5□00	1.5	100 kHz,1 V	0.0081	10.3(12.9)	7	T	1R5
BPSC001011512R2□00	2.2	100 kHz,1 V	0.011	9.2(11)	6.3	T	2R2
BPSC001011513R3□00	3.3	100 kHz,1 V	0.012	7.2(9)	6.1	T	3R3
BPSC001011514R7□00	4.7	100 kHz,1 V	0.014	5.6(7.8)	5	M,T	4R7
BPSC001011516R8□00	6.8	100 kHz,1 V	0.024	5.1(6.4)	4.7	M,T	6R8
BPSC001011518R2□00	8.2	100 kHz,1 V	0.027	4.7(5.9)	4.4	M,T	8R2
BPSC00101151100□00	10	100 kHz,1 V	0.028	4.4(5.6)	4.2	M,T	100
BPSC00101151120□00	12	100 kHz,1 V	0.036	3.4(5.8)	3.6	M,T	120
BPSC00101151150□00	15	100 kHz,1 V	0.041	3.2(4.5)	3.4	M,T	150
BPSC00101151180□00	18	100 kHz,1 V	0.046	3.0(3.8)	3.1	M,T	180
BPSC00101151220□00	22	100 kHz,1 V	0.061	2.8(3.6)	2.9	M,T	220
BPSC00101151270□00	27	100 kHz,1 V	0.069	2.1(3.2)	2.6	M,T	270
BPSC00101151330□00	33	100 kHz,1 V	0.084	2.0(2.9)	2.5	M,T	330
BPSC00101151390□00	39	100 kHz,1 V	0.106	1.9(2.6)	2.25	M,T	390
BPSC00101151470□00	47	100 kHz,1 V	0.13	1.7(2.3)	2	M,T	470
BPSC00101151560□00	56	100 kHz,1 V	0.149	1.6(2.2)	1.9	M,T	560
BPSC00101151680□00	68	100 kHz,1 V	0.201	1.5(2.0)	1.6	M,T	680
BPSC00101151820□00	82	100 kHz,1 V	0.227	1.3(1.8)	1.45	M,T	820
BPSC00101151101□00	100	100 kHz,1 V	0.253	1.2(1.7)	1.35	M,T	101
BPSC00101151121□00	120	100 kHz,1 V	0.303	1.1(1.5)	1.18	M,T	121
BPSC00101151151□00	150	100 kHz,1 V	0.42	1.0(1.3)	1	M,T	151
BPSC00101151181□00	180	100 kHz,1 V	0.45	0.9(1.2)	0.9	M,T	181
BPSC00101151221□00	220	100 kHz,1 V	0.54	0.8(1.1)	0.85	M,T	221
BPSC00101151271□00	270	100 kHz,1 V	0.672	0.75(0.99)	0.8	M,T	271

**NOTE:** □-tolerance M=±20% / T=±30%

1. Operating temperature range - 4 0 °C ~ 1 2 5 °C(Including self - temperature rise)
2. Isat for Inductance drop 35% from its value without current.
3. Irms for a 40 °C temperature rise from 25 °C ambient.

## BPSC00101151 Series Specification

Part No.	Inductance ( $\mu$ H )	Test Freq.	RDC ( $\Omega$ )Max.	Isat(A) Max(Typ)	Irms (A)Typ.	Tolerance	Marking
BPSC00101151331□00	330	100 kHz,1 V	0.812	0.74(0.92)	0.73	M,T	331
BPSC00101151391□00	390	100 kHz,1 V	0.953	0.62(0.83)	0.7	M,T	391
BPSC00101151471□00	470	100 kHz,1 V	1.29	0.6(0.77)	0.54	M,T	471
BPSC00101151561□00	560	100 kHz,1 V	1.43	0.47(0.71)	0.52	M,T	561
BPSC00101151681□00	680	100 kHz,1 V	1.6	0.46(0.65)	0.51	M,T	681
BPSC00101151821□00	820	100 kHz,1 V	1.77	0.42(0.57)	0.48	M,T	821
BPSC00101151102□00	1000	100 kHz,1 V	2.2	0.40(0.54)	0.4	M,T	102

## BPSC00101151 Series Specification

### 8 BPSC00101151 Series

#### 8.1 Construction:

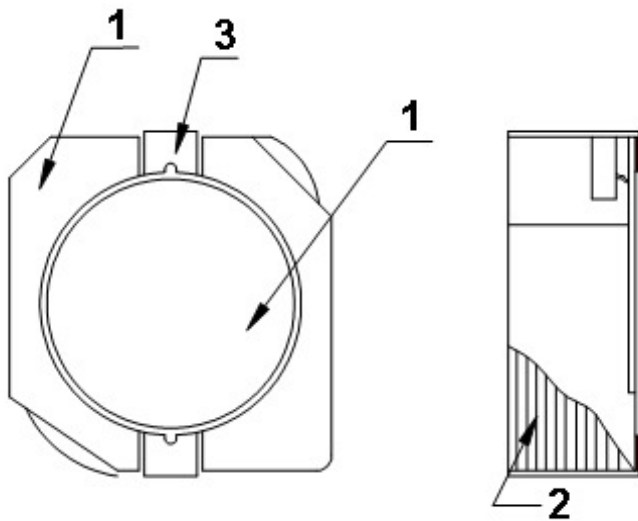

#### 8.2 Material List:

No	Part	Material
1	CORE	FERRITE
2	WIRE	MAGNET WIRE
3	TERMINAL	TERMINAL COPPER

## BPSC00101151 Series Specification

### 9 Reliability Of Ferrite Wire Wound Power Inductor

#### 1-1.Mechanical Performance

No	Item	Specification	Test Method
1-1-1	Vibration	Appearance: No damage Inductance: within $\pm 10\%$ of initial value	Test device shall be soldered on the substrate Oscillation Frequency: 10 to 55 to 10Hz for 1min Amplitude: 1.5mm Time: 2hrs for each axis (X, Y & Z), total 6hrs
1-1-2	Resistance to Soldering Heat	Appearance: No damage	Pre-heating: 150°C, 1min Solder Composition: Sn/Ag3.0/Cu0.5 Solder Temperature: 260 $\pm$ 5°C Immersion Time: 10 $\pm$ 1sec
1-1-3	Solder ability	The electrodes shall be at least 95% covered with new solder coating	Pre-heating: 150°C, 1min Solder Composition: Sn/Ag3.0/Cu0.5 Solder Temperature: 245 $\pm$ 5°C Immersion Time: 4 $\pm$ 1sec
1-1-4	Resistance to solvent	There must be no change in appearance or obliteration of marking.	Inductors must withstand 6 minutes of alcohol or water.

#### 1-2.Environmental Performance

No	Item	Specification	Test Method															
1-2-1	Temperature Shock	Appearance: No damage Inductance: within $\pm 10\%$ of initial value	10 cycles (Air to Air) 1 cycles shall consist of: 30 minutes exposure to -55 °C 30 minutes exposure to 125 °C 15 seconds maximum transition between temperatures															
1-2-2	Temperature Cycle		One cycle: <table border="1"> <thead> <tr> <th>Step</th> <th>Temperature (°C)</th> <th>Time (min)</th> </tr> </thead> <tbody> <tr> <td>1</td> <td>-40<math>\pm</math>3</td> <td>30</td> </tr> <tr> <td>2</td> <td>25<math>\pm</math>2</td> <td>3</td> </tr> <tr> <td>3</td> <td>125<math>\pm</math>3</td> <td>30</td> </tr> <tr> <td>4</td> <td>25<math>\pm</math>2</td> <td>3</td> </tr> </tbody> </table>	Step	Temperature (°C)	Time (min)	1	-40 $\pm$ 3	30	2	25 $\pm$ 2	3	3	125 $\pm$ 3	30	4	25 $\pm$ 2	3
Step	Temperature (°C)		Time (min)															
1	-40 $\pm$ 3		30															
2	25 $\pm$ 2		3															
3	125 $\pm$ 3	30																
4	25 $\pm$ 2	3																
1-2-3	Humidity Resistance	Temperature: 40 $\pm$ 2°C Relative Humidity: 90 ~ 95% Time: 1000hrs Measured after exposure in the room condition for 24hrs																
1-2-4	Heat Life	Temperature: 85 $\pm$ 3°C Applied Current: Rated Current Time: 1000hrs Measured after exposure in the room condition for 24hrs																
1-2-5	Cold Resistance	Temperature: -40 $\pm$ 3°C Time: 1000hrs Measured after exposure in the room condition for 24hrs																

**BPSC00101151 Series Specification**

Reflow Soldering Profile

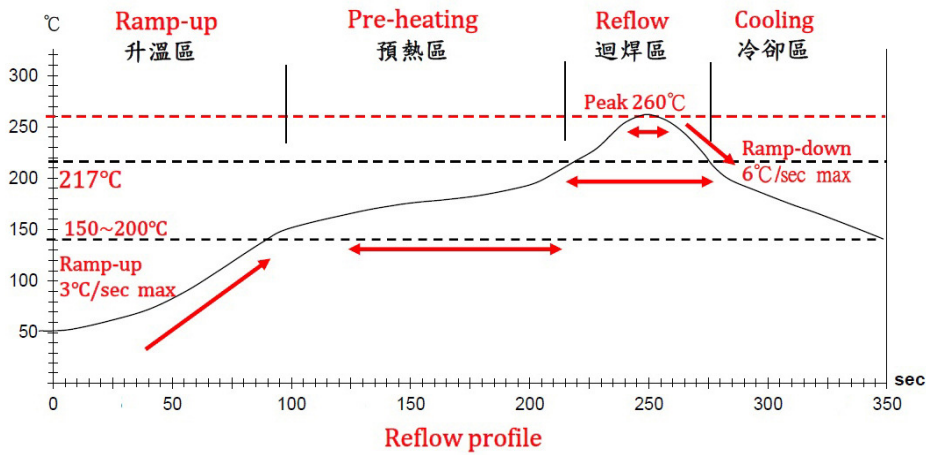

Lead-Free(LF)標準溫度分析範圍

Refer to J-STD-020C

管制項目 Item.	升温區 Ramp-up	预热區 Pre-heating	迴焊區 Reflow	Peak Temp	冷却區 Cooling
溫度範圍 Temp.scope	R.T ~ 150°C	150°C ~ 200°C	217°C	260±5°C	Peak Temp.~150°C
標準時間 Time spec.	-	60 ~ 180 sec	60 ~ 150 sec	20 ~ 40 sec	-
實際時間 Time result	-	75 ~ 100 sec	90 ~ 120 sec	20 ~ 35 sec	-

## BPSC00101151 Series Specification

### 10 Packaging:

#### 10.1 Packaging -Cover Tape

The force for tearing off cover tape is 10 to 130 grams in the arrow direction.

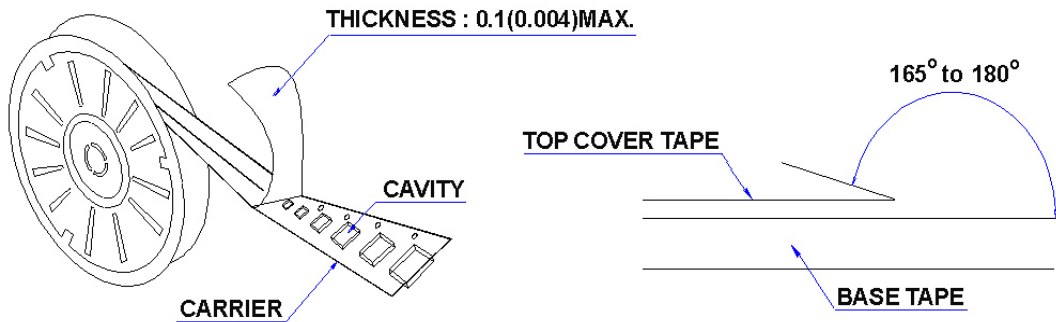

#### 10.2 Packaging Quantity

TYPE	PCS/REEL
101151	500

#### 10.3 Reel Dimensions

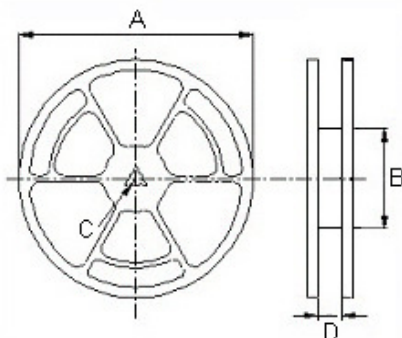

Dimensions in mm

TYPE	A	B	C	D
101151	330	100	13	24.4

## BPSC00101151 Series Specification

### 10 Packaging:

#### 10.4 Tape Dimensions in mm

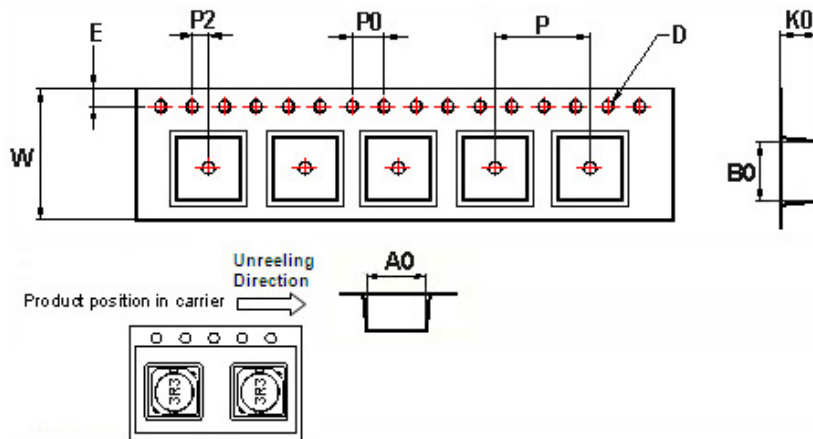

TYPE	A0	B0	K0	D	E	W	P	P0	P2
101151	10.6	10.6	5.0	1.55	1.75	24	16	4	2

### 11 Recommended Land Pattern:

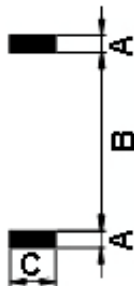

Dimensions in mm

TYPE	A	B	C
101151	1.6	7.3	3.2

### 12 Note:

1. Please make sure that your product has been evaluated and confirmed against your specifications when our product is mounted to your product.
2. Do not knock nor drop.
3. All the items and parameters in this product specification have been prescribed on the premise that our product is used for the purpose, under the condition and in the environment agreed upon between you and us. You are requested not to use our product deviating from such agreement.
4. Please keep the distance between transformer/coil and other components (refer to the standard IEC 950)
5. The moisture sensitivity level (MSL) of products is classified as level 1.

# BPSC00101151 Series Specification

**13** Graph:

BPSC001011512R2□00

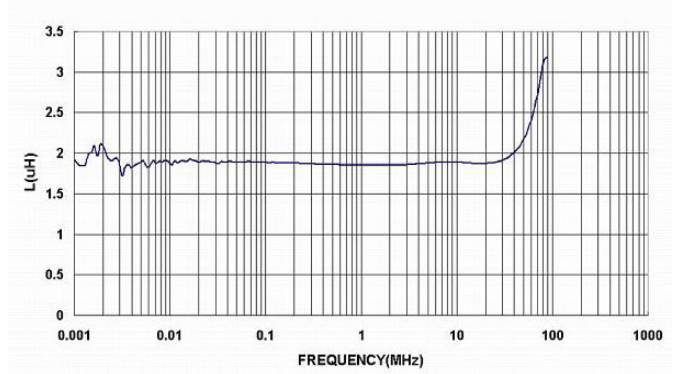
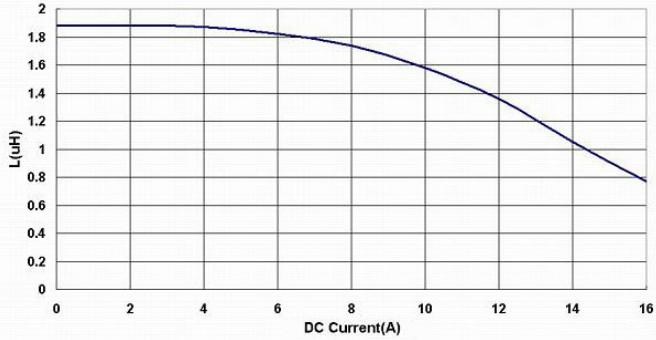

BPSC001011513R3□00

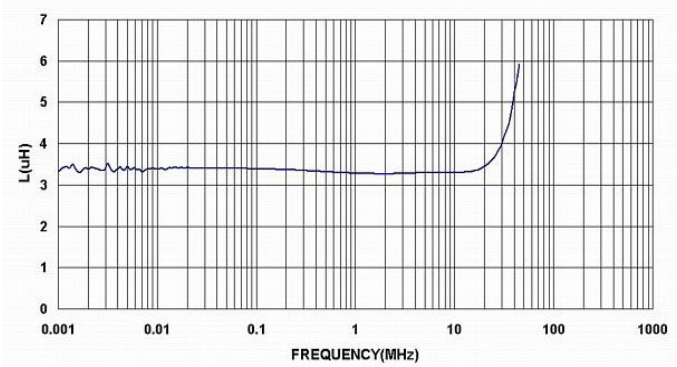
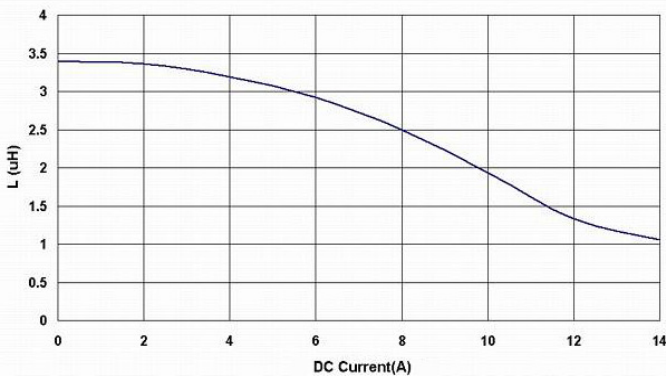

BPSC00101151821□00

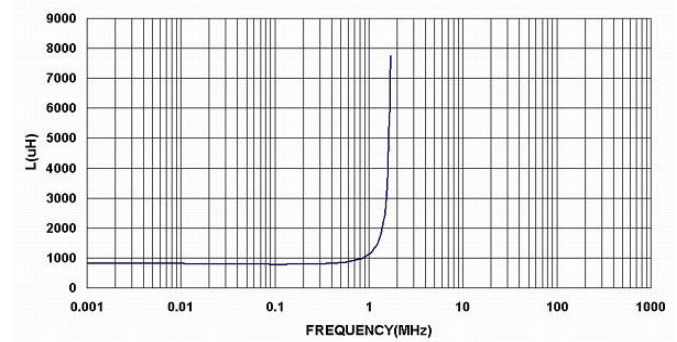
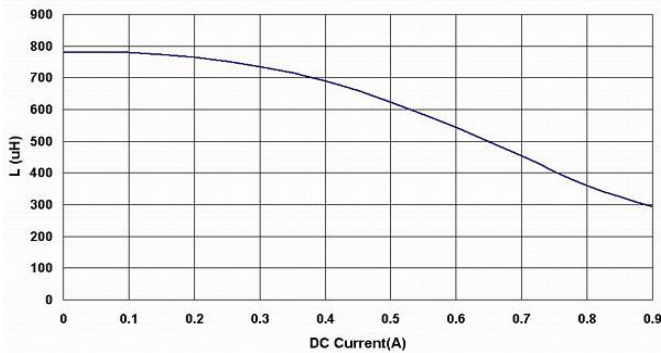

BPSC00101151102□00

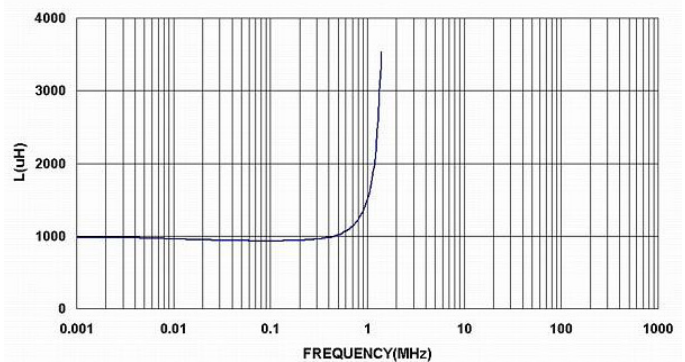
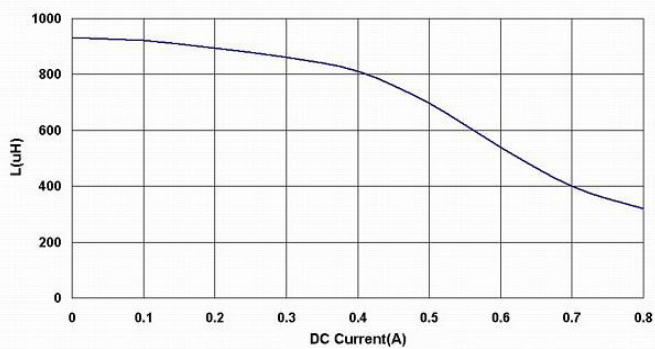

# BPSC00101151 Series Specification

**13** Graph:

BPSC001011514R7□00

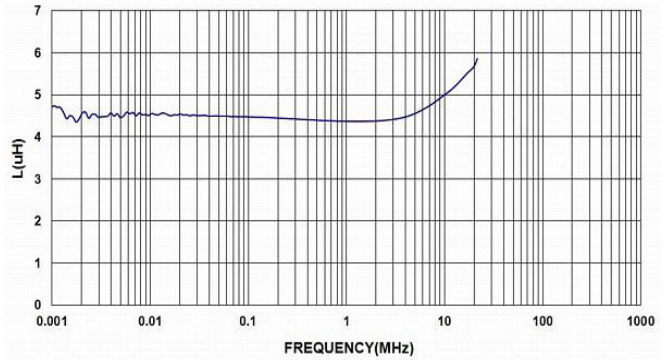
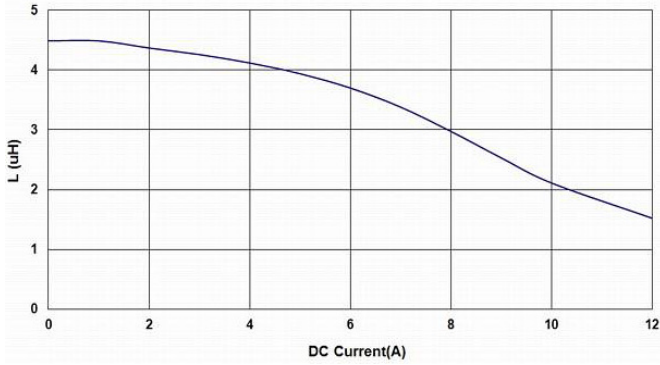

BPSC001011516R8□00

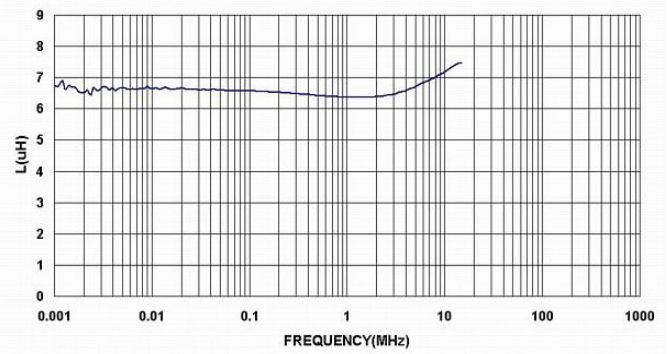

BPSC001011518R2□00

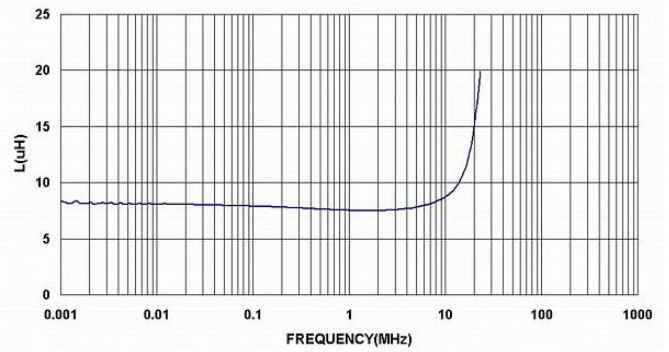

BPSC00101151100□00

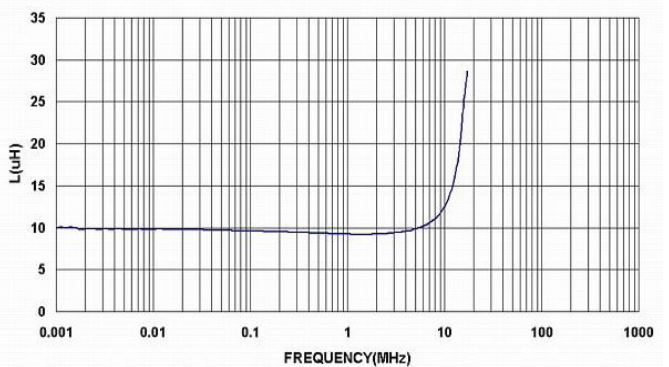
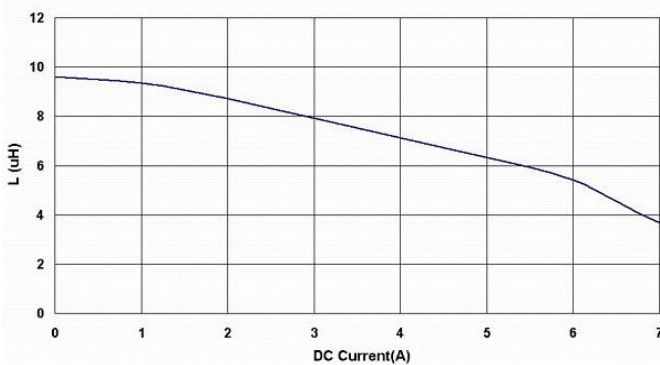

# BPSC00101151 Series Specification

**13** Graph:

BPSC00101151120□00

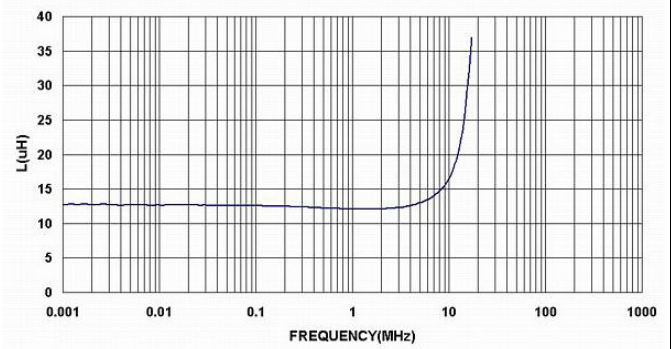
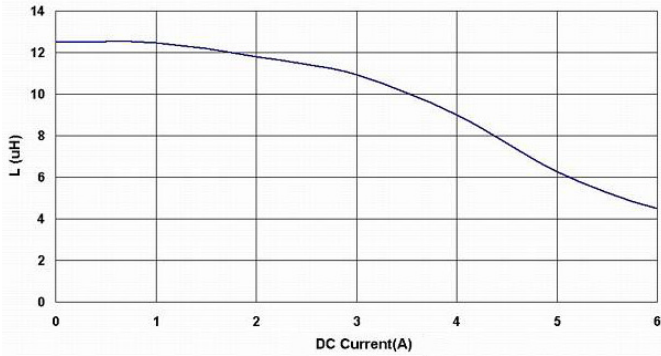

BPSC00101151150□00

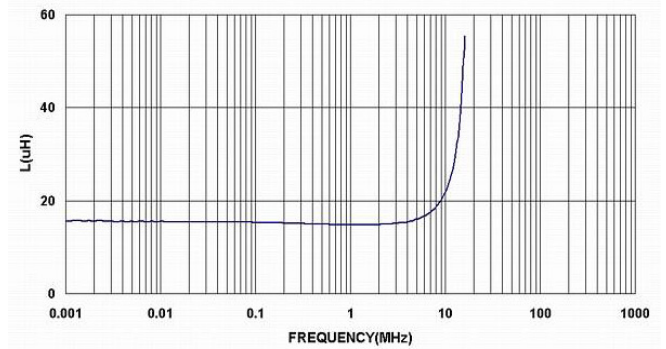
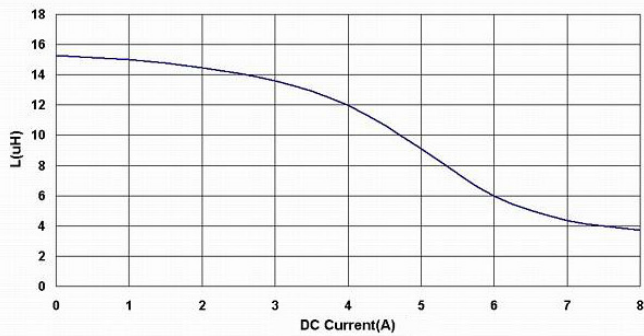

BPSC00101151180□00

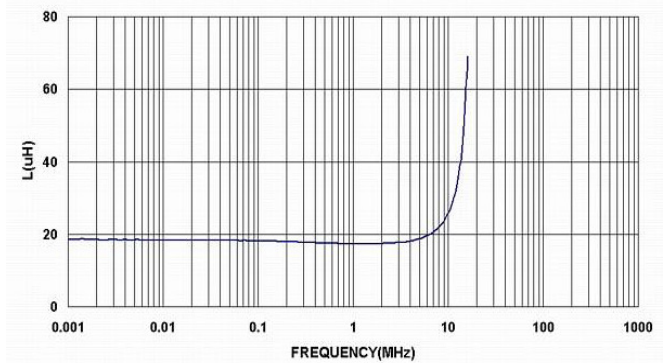

BPSC00101151220□00

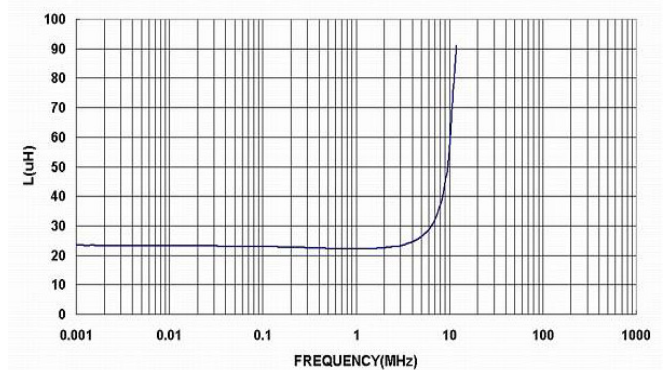
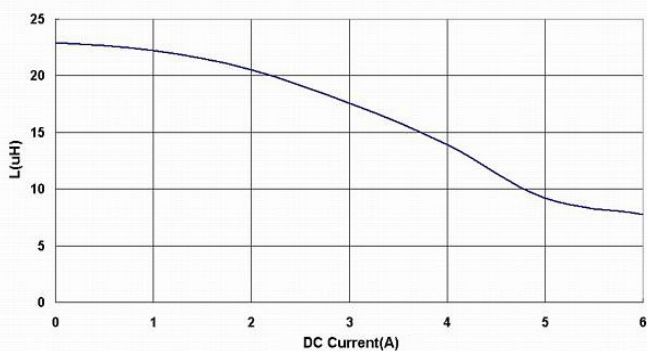

# BPSC00101151 Series Specification

**13** Graph:

BPSC00101151270□00

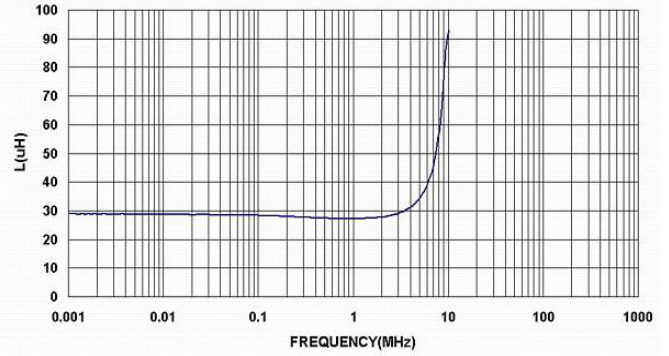
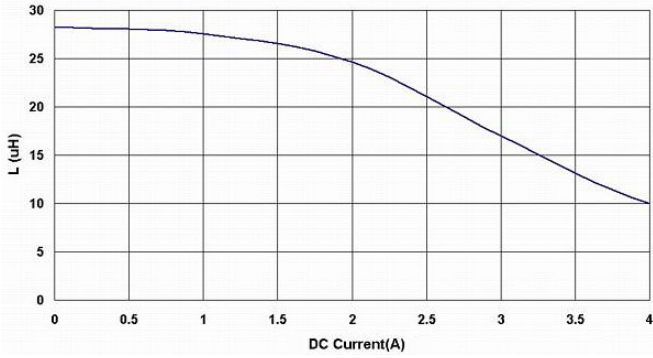

BPSC00101151330□00

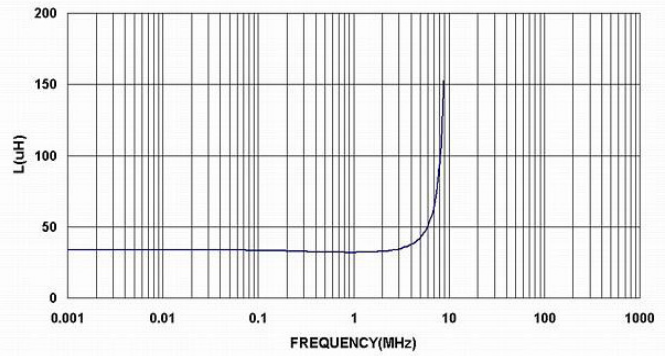
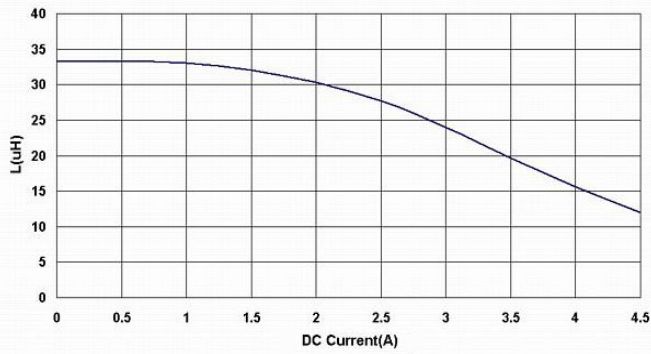

BPSC00101151390□00

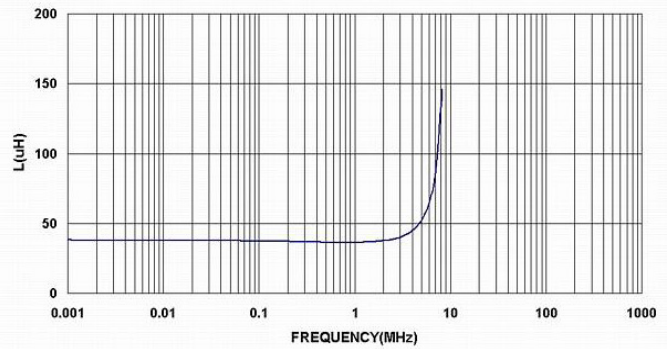
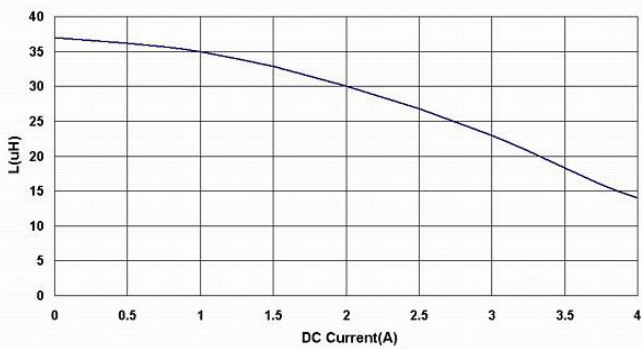

BPSC00101151470□00

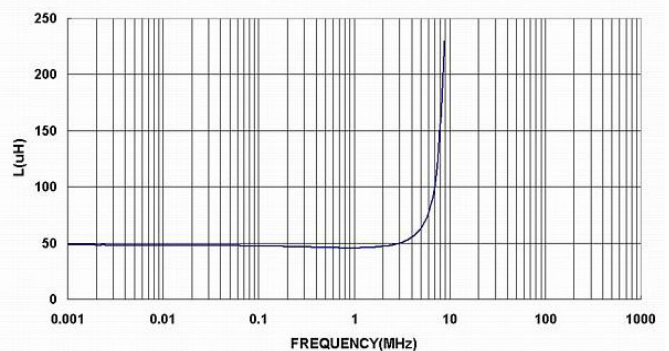
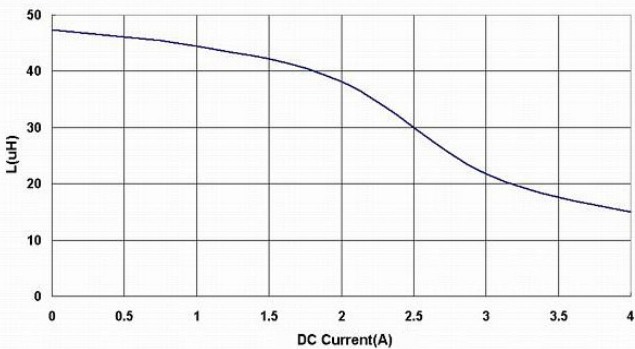

# BPSC00101151 Series Specification

**13** Graph:

BPSC00101151560□00

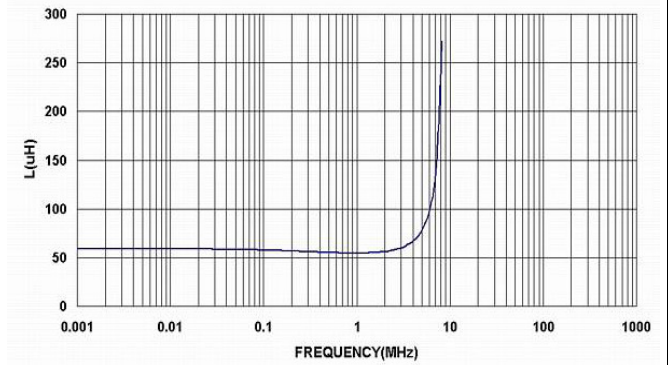
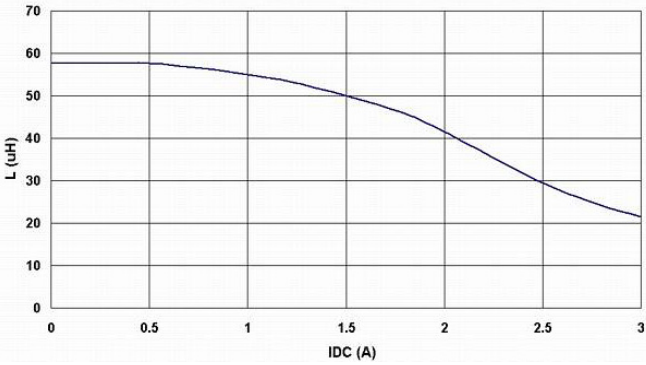

BPSC00101151680□00

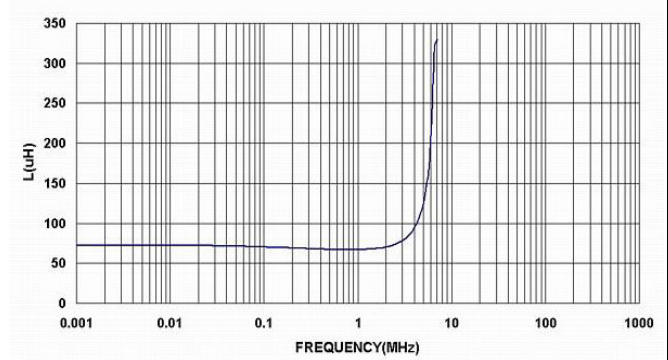
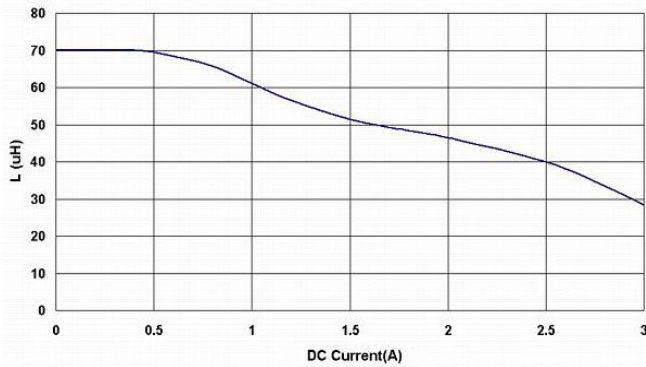

BPSC00101151820□00

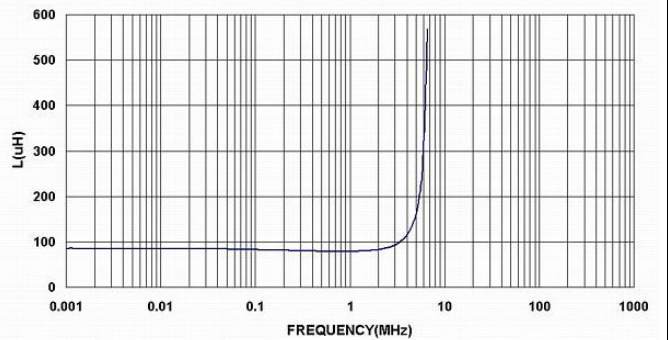
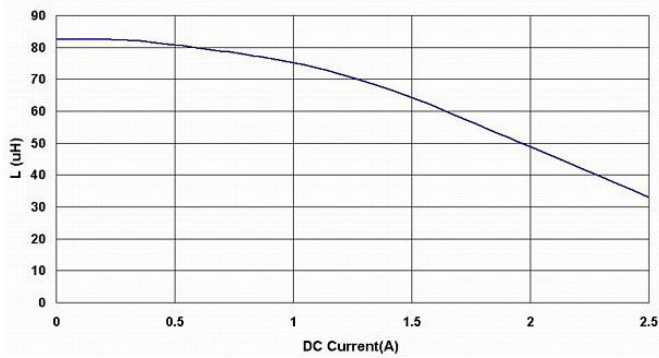

BPSC00101151101□00

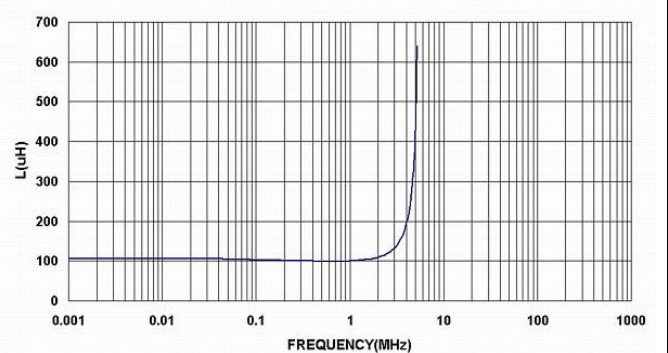
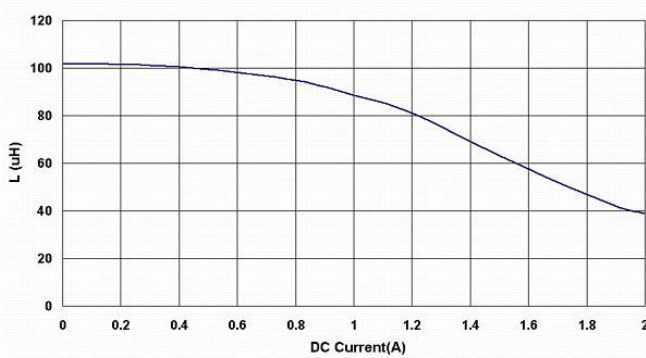

# BPSC00101151 Series Specification

**13** Graph:

BPSC00101151121□00

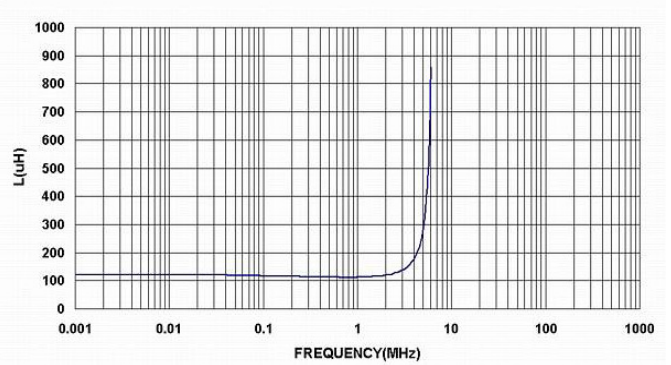
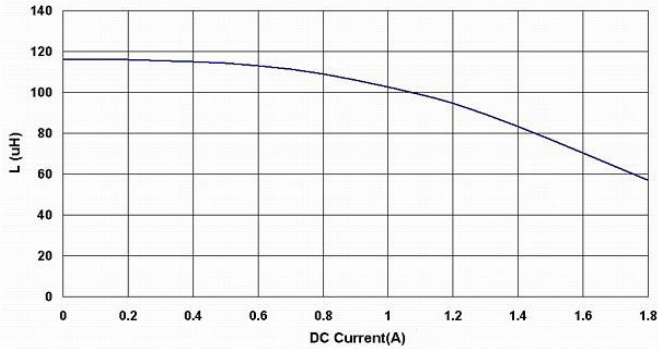

BPSC00101151151□00

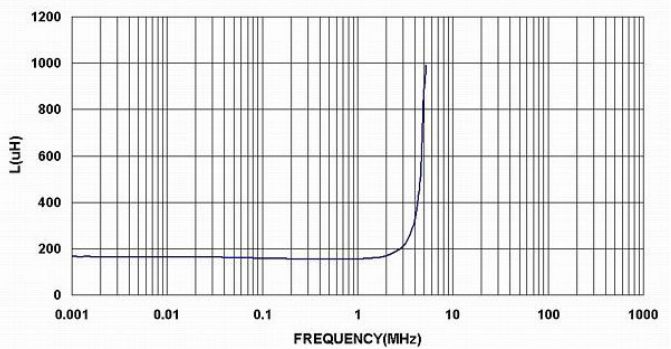
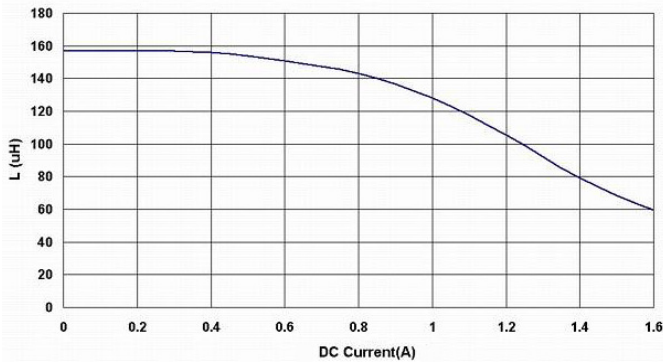

BPSC00101151181□00

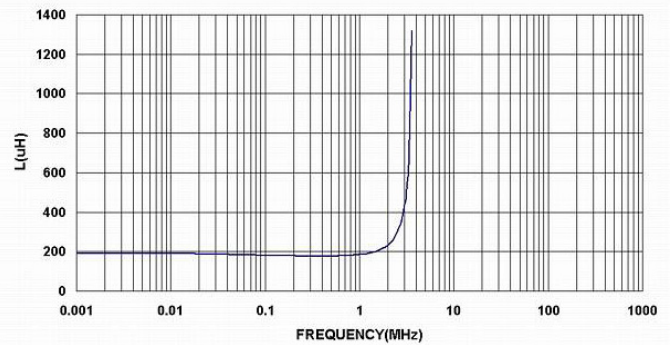
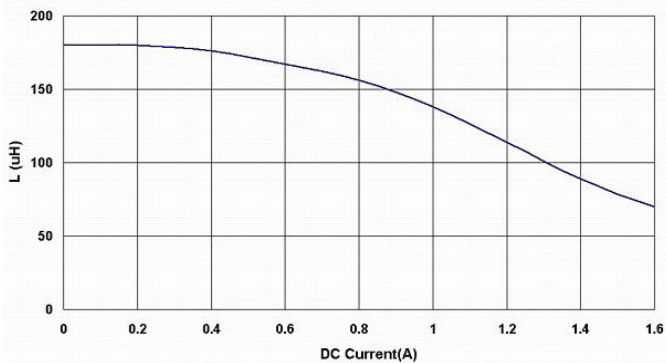

BPSC00101151221□00

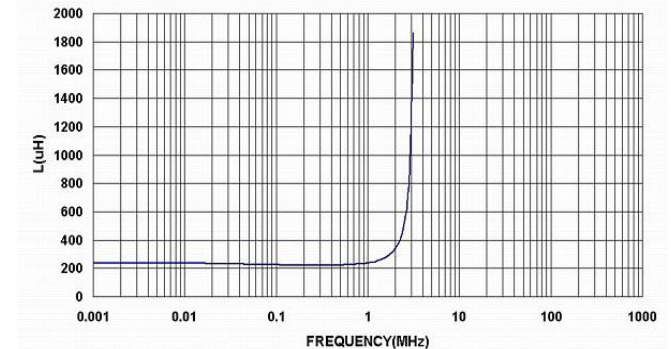
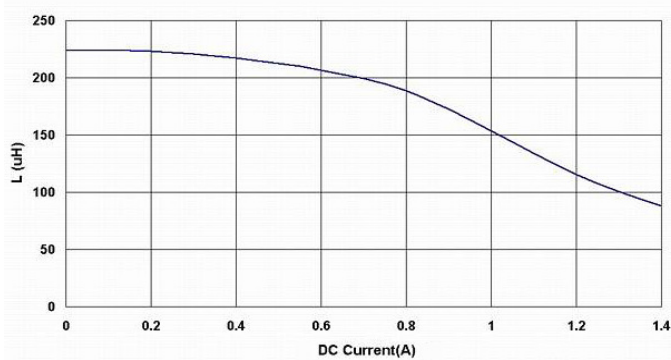

# BPSC00101151 Series Specification

**13** Graph:

BPSC00101151271□00

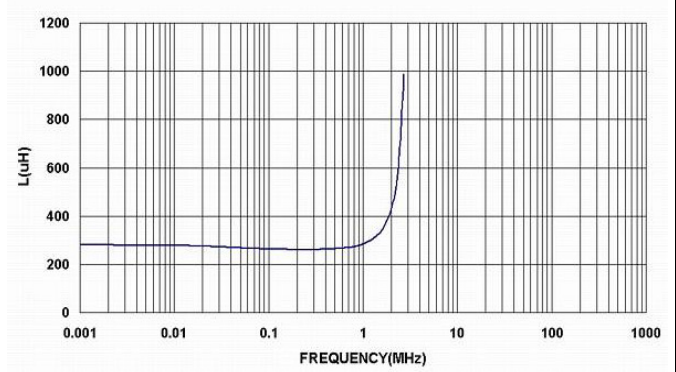
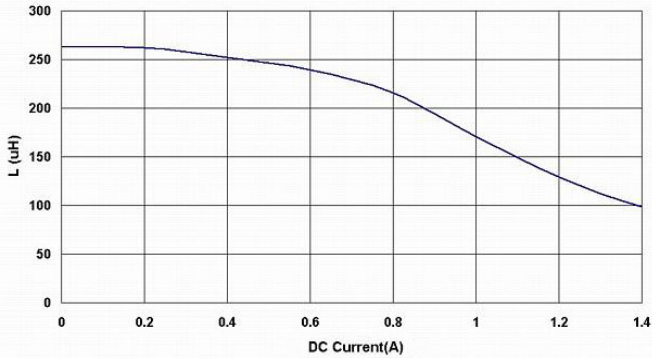

BPSC00101151331□00

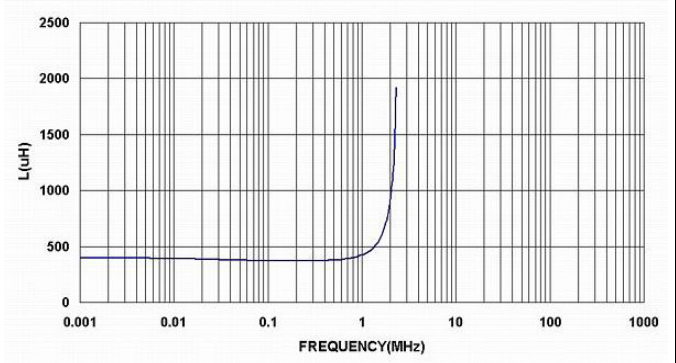
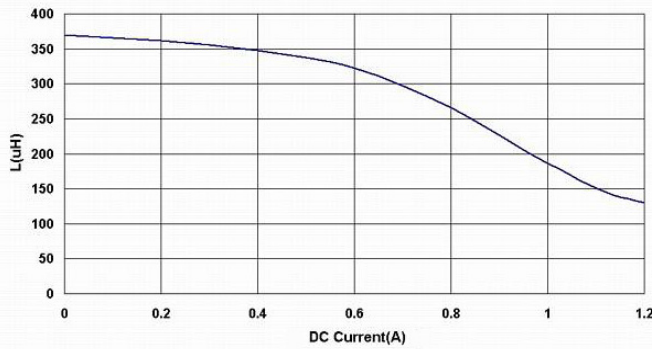

BPSC00101151391□00

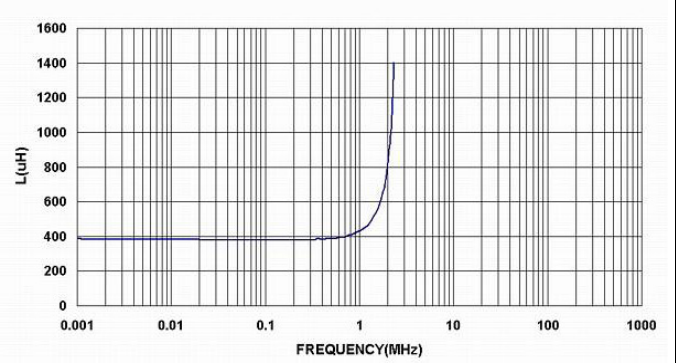
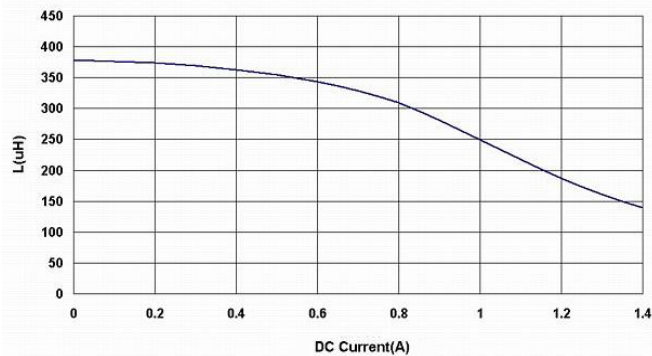

BPSC00101151471□00

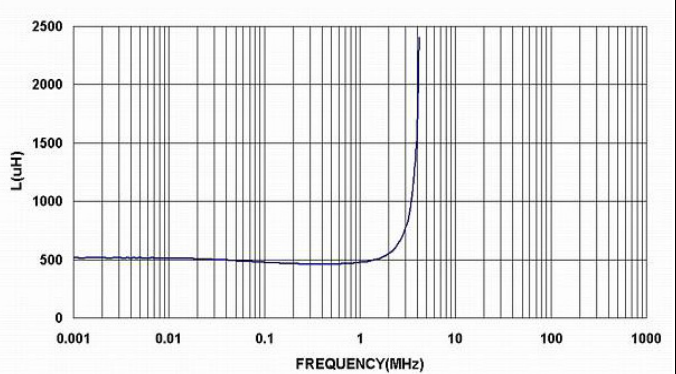
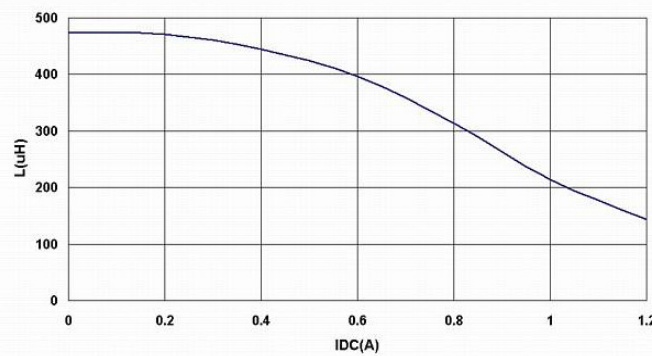

# BPSC00101151 Series Specification

**13** Graph:

BPSC00101151561□00

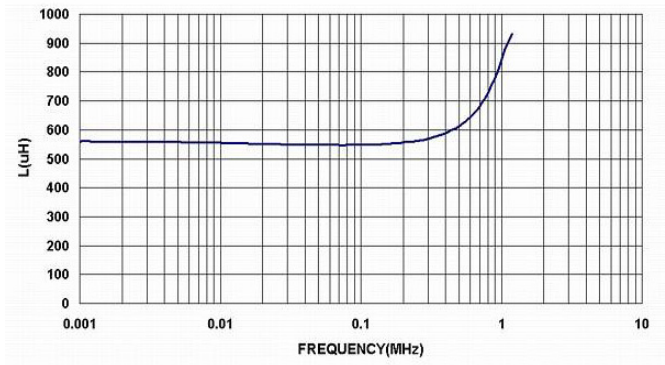
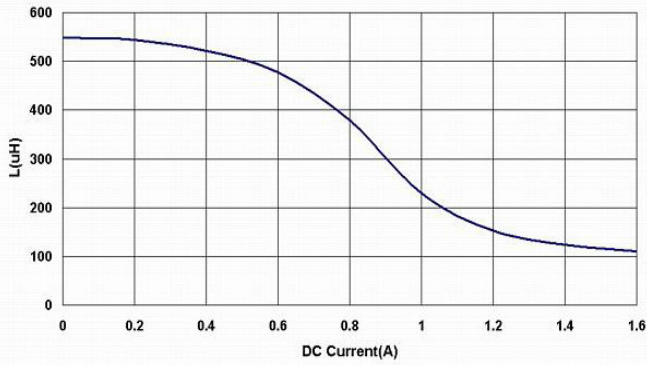

BPSC00101151681□00

