

# Power Inductor

## BPSC Series



### Overview

Power inductors are passive electronic components used in various circuits to store energy in a magnetic field when electrical current flows through them. They are critical in filtering, energy storage, and noise suppression in power electronic systems. They are designed to handle higher currents and are optimized for minimal power loss and thermal efficiency.

### Benefits

1. Ferrite SMD Shielded Type
2. No thermal aging

### Applications

1. AP Routers, STBs
2. LCD TVs and monitors
3. Game consoles
4. LED lightings
5. DC/DC converters

### Product Information

Series	L (mm)	W(mm)	T (mm)	Inductance (μH)
BPSC	3.2	3.2	1.55	0.47 ~ 3300
	3.2	3.2	2.0	
	4.0	4.0	1.2	
	4.0	4.0	1.8	
	4.0	4.0	3.0	
	4.7	4.7	2.0	
	4.7	4.7	3.0	
	4.7	4.7	4.0	
	5.7	5.7	2.0	
	5.7	5.7	3.0	
	6.7	6.7	3.0	
	7.3	7.3	3.4	
	7.0	7.0	4.0	
	7.3	7.3	4.5	
	8.3	8.3	4.5	
	10.3	10.5	3.1	
	10.3	10.5	4	
10.3	10.5	5.1		
12.5	12.5	4.5		
12.5	12.5	6		
12.5	12.5	8		
12.0	12.0	10.0		



## BPSC00060630 Series Specification

**1 Scope:** This specification applies to SMD Shielded Power Inductors

**2 Part Numbering:**

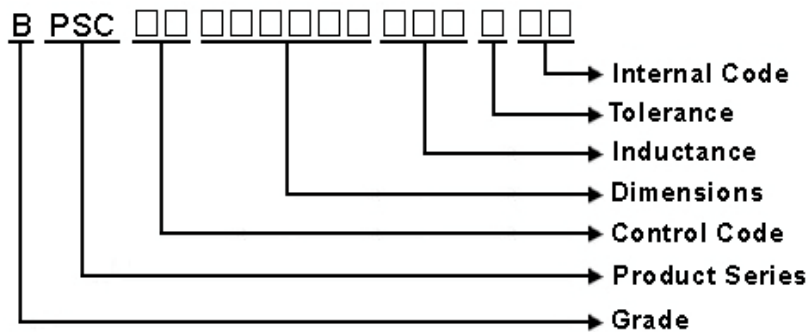

**3 Rating:**

Operating Temperature:  $-40^{\circ}\text{C} \sim +125^{\circ}\text{C}$  (Including self temp. rise)

Storage Temperature:  $-40^{\circ}\text{C} \sim +125^{\circ}\text{C}$  (For after the circuit board is mounted)

Storage Temperature: (on tape & reel):  $-20^{\circ}\text{C}$  to  $+40^{\circ}\text{C}$ ; 75% RH max.

**4 Marking:**

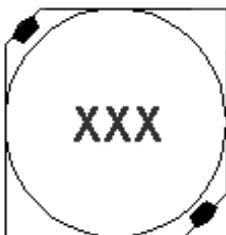

**Ex Marking : 3R3**

**Marking color : Black**

**5 Standard Testing Condition**

	Unless otherwise specified	In case of doubt
Temperature	Ordinary Temperature(15 to 35°C)	20 to 30°C
Humidity	Ordinary Humidity(25 to 85% RH)	50 to 80 %RH

## BPSC00060630 Series Specification

### 6 Configuration and Dimensions and Unit Weight:

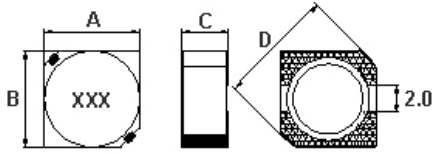

Dimensions in mm

TYPE	A	B	C	D
060630	5.7±0.3	5.7±0.3	3 Max.	8.2Max.

### Net Weight (grms)

SIZE CODE	Net Weight (grms)
060630	0.5(Typ.)

### 7 Electrical Characteristics:

Part No.	Inductance (uH)	Test Freq.	RDC (Ω)Max.	Isat(A) Max(Typ)	Tolerance (±%)	Marking
BPSC000606301R0□S0	1	10 kHz,1 V	0.015	3.50(4.20)	30	1R0
BPSC000606301R5□S0	1.5	10 kHz,1 V	0.015	2.80(3.70)	30	1R5
BPSC000606302R2□S0	2.2	10 kHz,1 V	0.018	2.40(3.10)	30	2R2
BPSC000606302R5□S0	2.5	10 kHz,1 V	0.022	2.30(2.70)	30	2R5
BPSC000606302R6□S0	2.6	10 kHz,1 V	0.022	2.20(2.60)	30	2R6
BPSC000606302R7□S0	2.7	10 kHz,1 V	0.024	2.20(2.60)	30	2R7
BPSC000606303R0□S0	3	10 kHz,1 V	0.024	2.20(2.50)	30	3R0
BPSC000606303R3□S0	3.3	10 kHz,1 V	0.027	2.10(2.50)	30	3R3
BPSC000606304R2□S0	4.2	10 kHz,1 V	0.031	2.00(2.20)	30	4R2
BPSC000606304R3□S0	4.3	10 kHz,1 V	0.041	1.80(2.10)	30	4R3
BPSC000606304R7□S0	4.7	10 kHz,1 V	0.038	1.60(2.00)	20,30	4R7
BPSC000606305R0□S0	5	10 kHz,1 V	0.038	1.50(1.90)	30	5R0
BPSC000606305R3□S0	5.3	10 kHz,1 V	0.038	1.50(1.90)	20,30	5R3
BPSC000606306R2□S0	6.2	10 kHz,1 V	0.045	1.20(1.80)	20,30	6R2
BPSC000606306R8□S0	6.8	10 kHz,1 V	0.05	1.20(1.60)	20,30	6R8
BPSC000606308R2□S0	8.2	10 kHz,1 V	0.053	1.00(1.50)	20,30	8R2
BPSC00060630100□S0	10	10 kHz,1 V	0.065	0.95(1.40)	20,30	100
BPSC00060630120□S0	12	10 kHz,1 V	0.076	0.90(1.30)	20,30	120
BPSC00060630150□S0	15	10 kHz,1 V	0.103	0.85(1.10)	20,30	150
BPSC00060630180□S0	18	10 kHz,1 V	0.11	0.80(1.00)	30	180
BPSC00060630220□S0	22	10 kHz,1 V	0.122	0.75(0.92)	20,30	220
BPSC00060630270□S0	27	10 kHz,1 V	0.175	0.65(0.82)	30	270
BPSC00060630330□S0	33	10 kHz,1 V	0.189	0.60(0.75)	30	330
BPSC00060630390□S0	39	10 kHz,1 V	0.212	0.55(0.70)	30	390
BPSC00060630470□S0	47	10 kHz,1 V	0.25	0.50(0.62)	20,30	470

**NOTE:** □-tolerance M=±20% / T=±30%

1. Operating temperature range - 3 0 °C ~ 1 0 0 °C(Including self - temperature rise)

2. Isat for Inductance drop 35% from its value without current.

3. RDC test method: place testing device to the 2 solder ends of winding and test the value.

## BPSC00060630 Series Specification

Part No.	Inductance ( $\mu$ H )	Test Freq.	RDC ( $\Omega$ )Max.	Isat(A) Max(Typ)	Tolerance ( $\pm$ %)	Marking
BPSC00060630560□S0	56	10 kHz,1 V	0.305	0.48(0.59)	30	560
BPSC00060630680□S0	68	10 kHz,1 V	0.355	0.42(0.52)	30	680
BPSC00060630820□S0	82	10 kHz,1 V	0.463	0.39(0.46)	30	820
BPSC00060630101□S0	100	10 kHz,1 V	0.52	0.35(0.42)	20,30	101
BPSC00060630181□S0	180	10 kHz,1 V	1.05	0.21(0.31)	30	181
BPSC00060630221□S0	220	10 kHz,1 V	1.2	0.20(0.30)	30	221
BPSC00060630331□S0	330	10 kHz,1 V	1.7	0.15(0.24)	20,30	331
BPSC00060630391□S0	390	10 kHz,1 V	1.8	0.13(0.22)	30	391
BPSC00060630471□S0	470	10 kHz,1 V	2.5	0.11(0.21)	20,30	471
BPSC00060630561□S0	560	10 kHz,1 V	3.2	0.10(0.17)	20,30	561

## BPSC00060630 Series Specification

### 8 BPSC00060630 Series

#### 8.1 Construction:

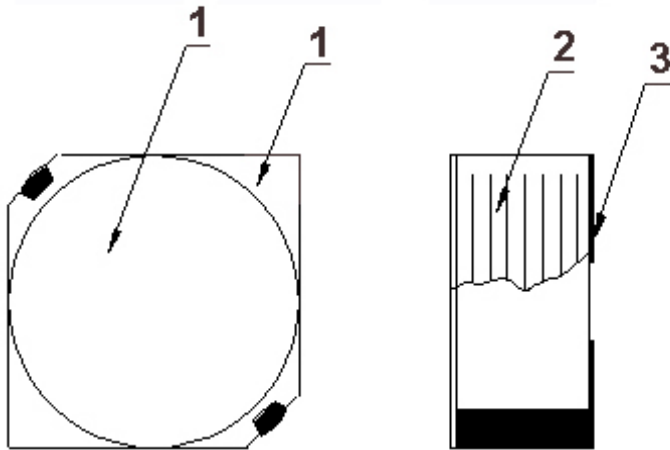

#### 8.2 Material List:

No	Part	Material
1	CORE	FERRITE
2	WIRE	MAGNET WIRE
3	TERMINAL	TERMINAL COPPER

## BPSC00060630 Series Specification

### 9 Reliability Of Ferrite Wire Wound Power Inductor

#### 1-1.Mechanical Performance

No	Item	Specification	Test Method
1-1-1	Vibration	Appearance: No damage L change: within±10%	Test device shall be soldered on the substrate Oscillation Frequency: 10 to 55 to 10Hz for 1min Amplitude: 1.5mm Time: 2hrs for each axis (X, Y & Z), total 6hrs
1-1-2	Resistance to Soldering Heat	Appearance: No damage	Pre-heating: 150°C, 1min Solder Composition: Sn/Ag3.0/Cu0.5 Solder Temperature: 260±5°C Immersion Time: 10±1sec
1-1-3	Solderability	The electrodes shall be at least 95% covered with new solder coating	Pre-heating: 150°C, 1min Solder Composition: Sn/Ag3.0/Cu0.5 Solder Temperature: 245±5°C Immersion Time: 4±1sec
1-1-4	Resistance to solvent	There must be no change in appearance or obliteration of marking.	Inductors must withstand 6 minutes of alcohol or water.

#### 1-2.Environmental Performance

No	Item	Specification	Test Method															
1-2-1	Temperature Shock	Appearance: No damage L change: within±10%	10 cycles (Air to Air) 1 cycles shall consist of: 30 minutes exposure to -55 °C 30 minutes exposure to 130 °C 15 seconds maximum transition between temperatures Measured after exposure in the room condition for 24hrs															
1-2-2	Temperature Cycle		One cycle: <table border="1"> <thead> <tr> <th>Step</th> <th>Temperature (°C)</th> <th>Time (min)</th> </tr> </thead> <tbody> <tr> <td>1</td> <td>-30±3</td> <td>30</td> </tr> <tr> <td>2</td> <td>25±2</td> <td>3</td> </tr> <tr> <td>3</td> <td>100±3</td> <td>30</td> </tr> <tr> <td>4</td> <td>25±2</td> <td>3</td> </tr> </tbody> </table>	Step	Temperature (°C)	Time (min)	1	-30±3	30	2	25±2	3	3	100±3	30	4	25±2	3
Step	Temperature (°C)	Time (min)																
1	-30±3	30																
2	25±2	3																
3	100±3	30																
4	25±2	3																
1-2-3	Humidity Resistance		Temperature: 40±2°C Relative Humidity: 90 ~ 95% Time: 1000hrs Measured after exposure in the room condition for 24hrs															
1-2-4	High Temperature Resistance		Temperature: 85±3°C Applied Current: Rated Current Time: 1000hrs Measured after exposure in the room condition for 24hrs															
1-2-5	Low Temperature Resistance		Temperature: -30±3°C Time: 1000hrs Measured after exposure in the room condition for 24hrs															

## BPSC00060630 Series Specification

### Reflow Soldering Profile

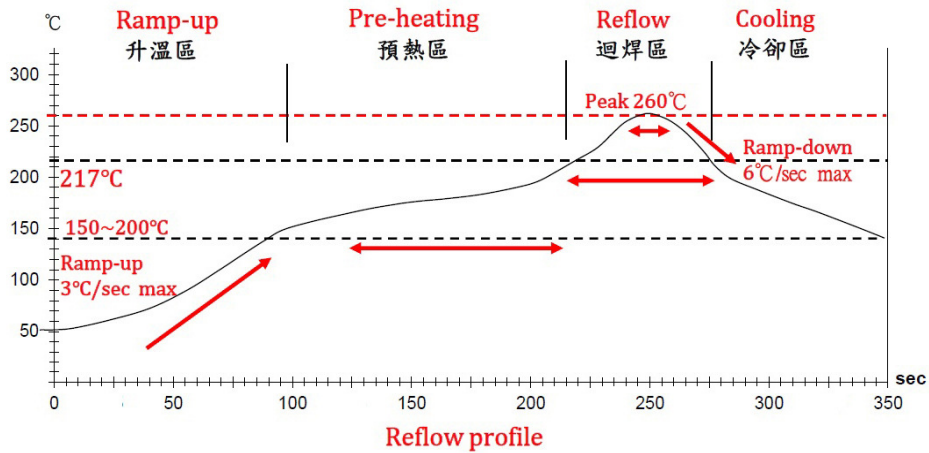

Lead-Free(LF)標準溫度分析範圍

Refer to J-STD-020C

管制項目 Item.	升温區 Ramp-up	預熱區 Pre-heating	迴焊區 Reflow	Peak Temp	冷卻區 Cooling
溫度範圍 Temp.scope	R.T ~ 150°C	150°C ~ 200°C	217°C	260±5°C	Peak Temp.~150°C
標準時間 Time spec.	-	60 ~ 180 sec	60 ~ 150 sec	20 ~ 40 sec	-
實際時間 Time result	-	75 ~ 100 sec	90 ~ 120 sec	20 ~ 35 sec	-

## BPSC00060630 Series Specification

### 10 Packaging:

#### 10.1 Packaging -Cover Tape

The force for tearing off cover tape is 10 to 130 grams in the arrow direction.

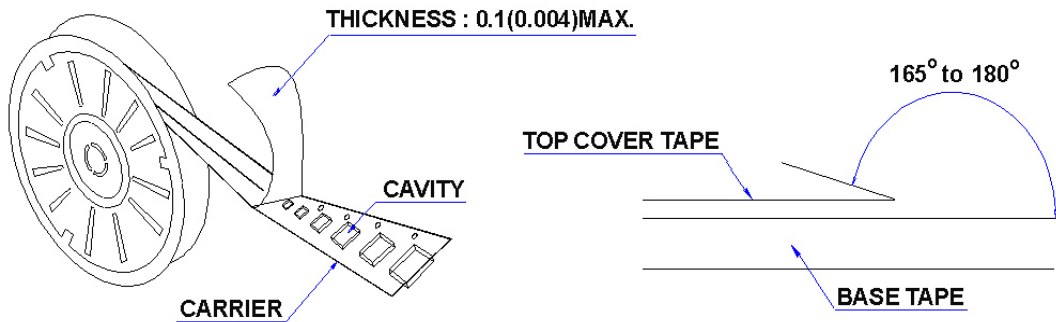

#### 10.2 Packaging Quantity

TYPE	PCS/REEL
060630	1500

#### 10.3 Reel Dimensions

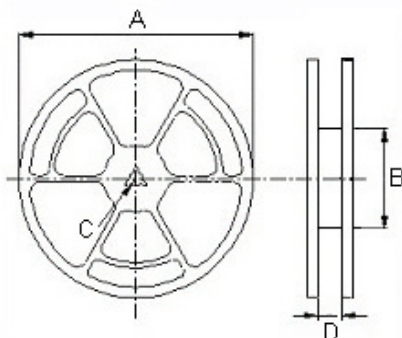

Dimensions in mm

TYPE	A	B	C	D
060630	330	100	13	16

## BPSC00060630 Series Specification

### 10 Packaging:

#### 10.4 Tape Dimensions in mm

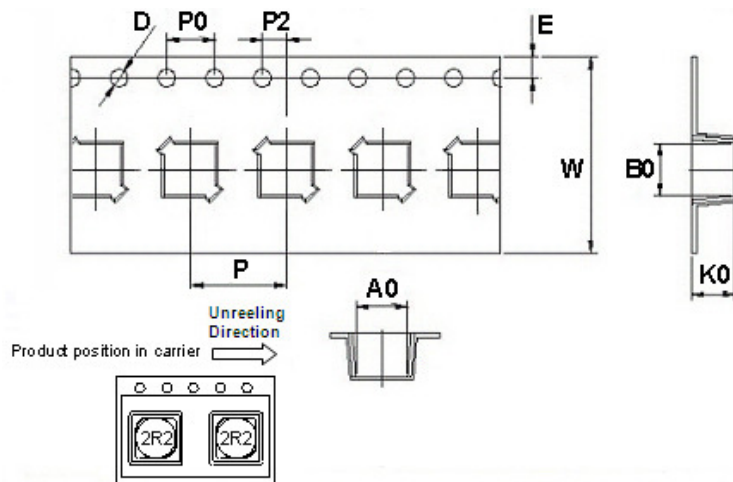

TYPE	A0	B0	K0	D	E	W	P	P0	P2
060630	6.2	6.2	3.1	1.55	1.75	18	12	4	2

### 11 Recommended Land Pattern:

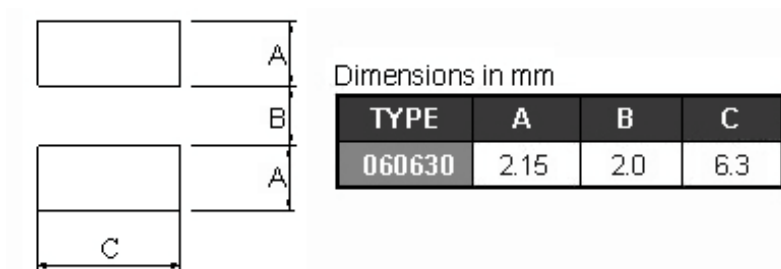

### 12 Note:

1. Please make sure that your product has been evaluated and confirmed against your specifications when our product is mounted to your product.
2. Do not knock nor drop.
3. All the items and parameters in this product specification have been prescribed on the premise that our product is used for the purpose, under the condition and in the environment agreed upon between you and us. You are requested not to use our product deviating from such agreement.
4. Please keep the distance between transformer/coil and other components (refer to the standard IEC 950)
5. The moisture sensitivity level (MSL) of products is classified as level 1.

# BPSC00060630 Series Specification

**13** Graph:

BPSC000606301R0□S0

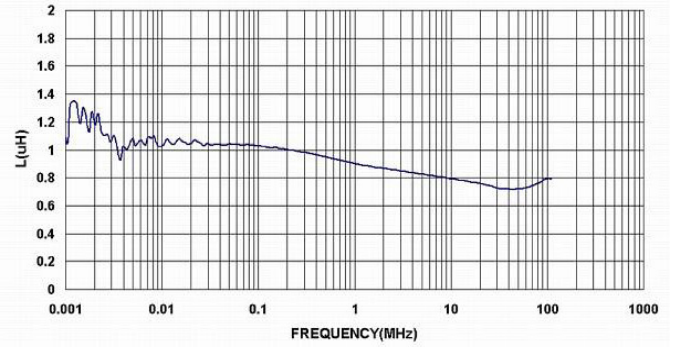
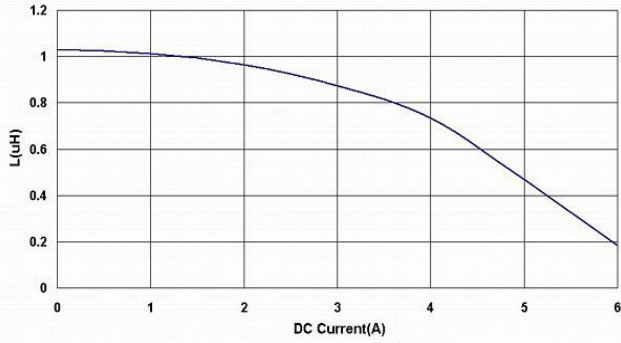

BPSC000606301R5□S0

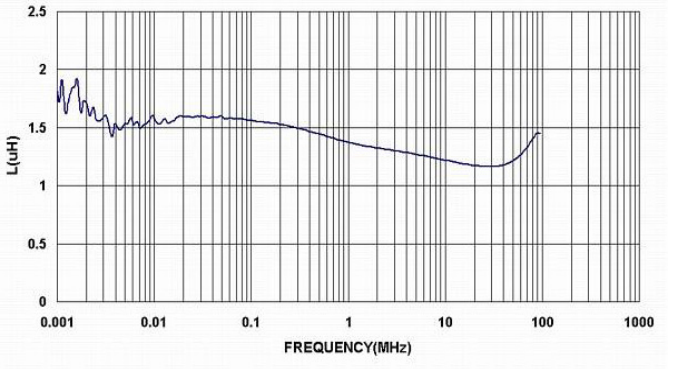
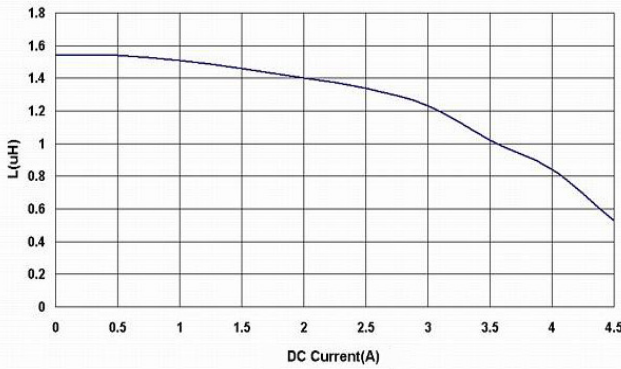

BPSC000606302R2□S0

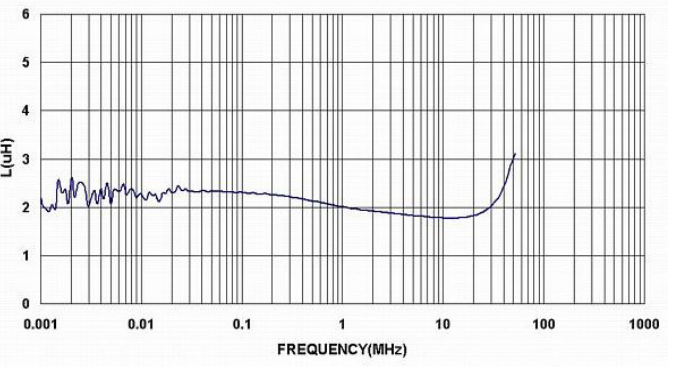
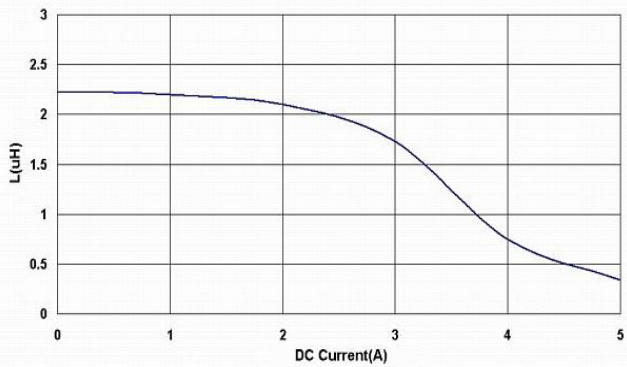

BPSC000606302R5□S0

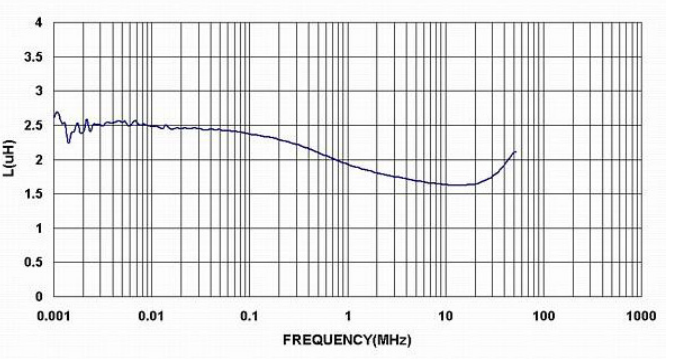
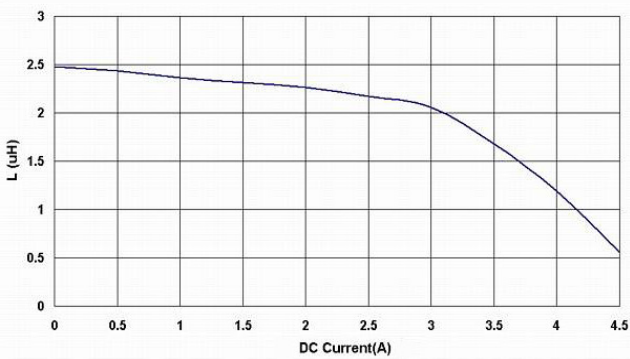

# BPSC00060630 Series Specification

**13** Graph:

BPSC000606303R0□S0

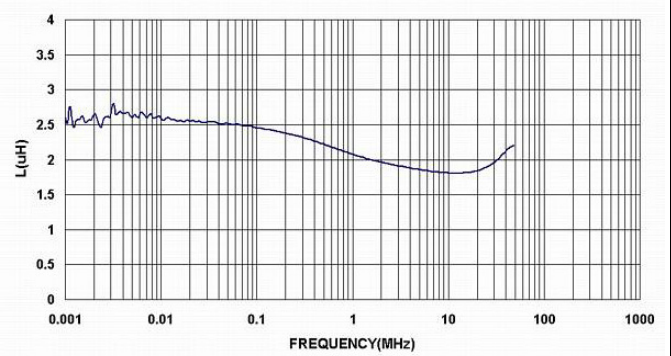
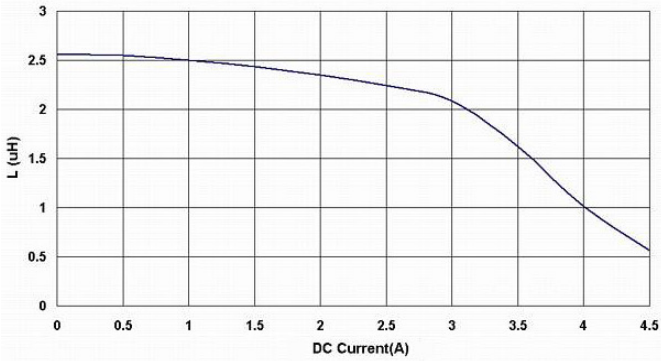

BPSC000606303R3□S0

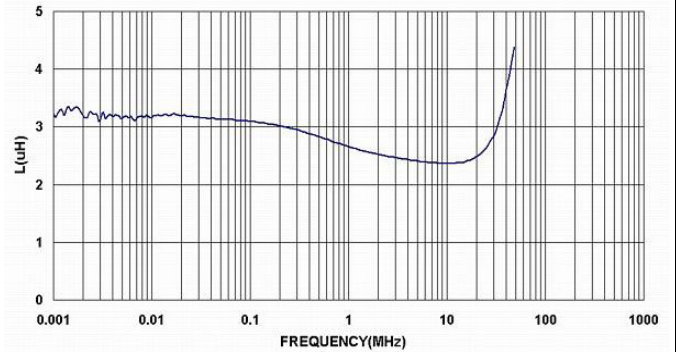
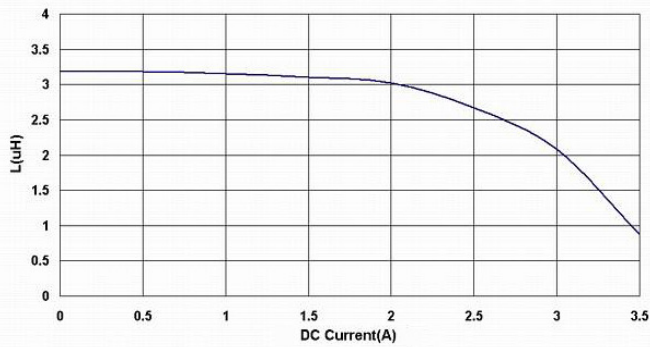

BPSC000606304R2□S0

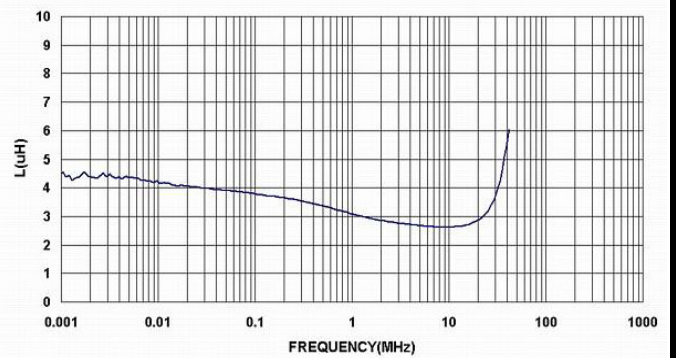
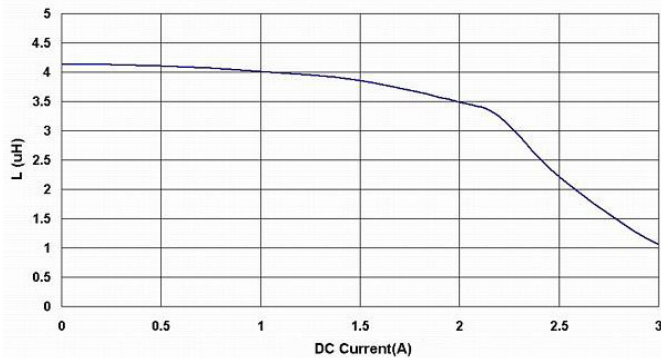

BPSC000606304R7□S0

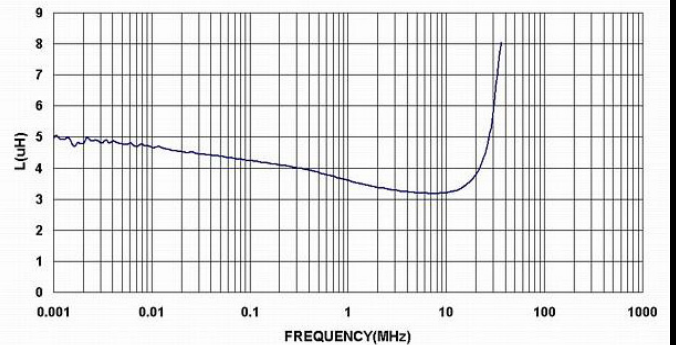
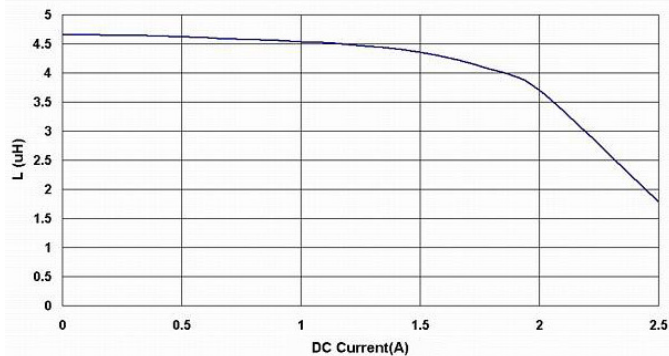

# BPSC00060630 Series Specification

**13** Graph:

BPSC000606305R3□S0

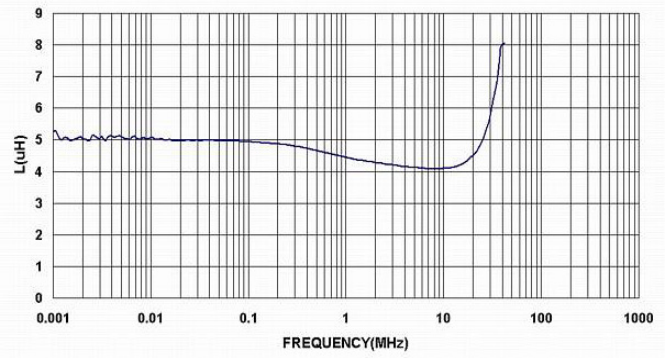
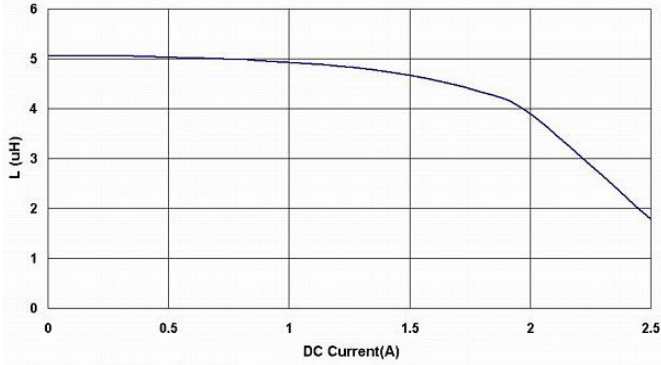

BPSC000606306R2□S0

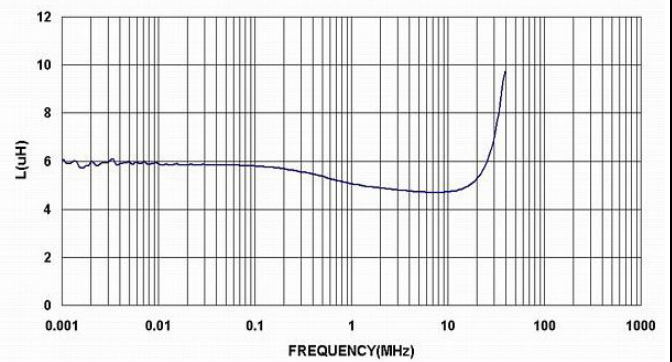
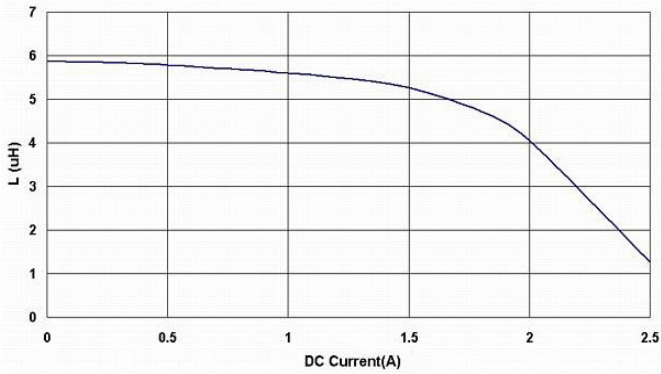

BPSC000606306R8□S0

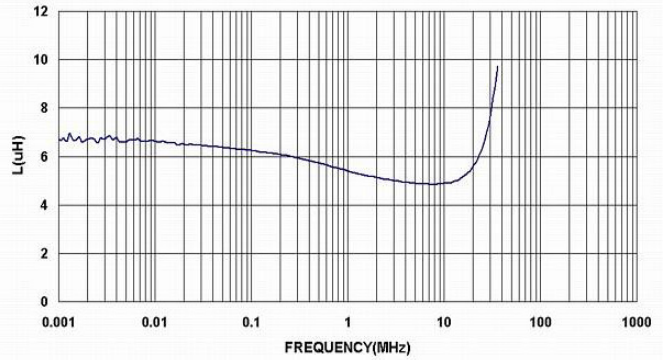
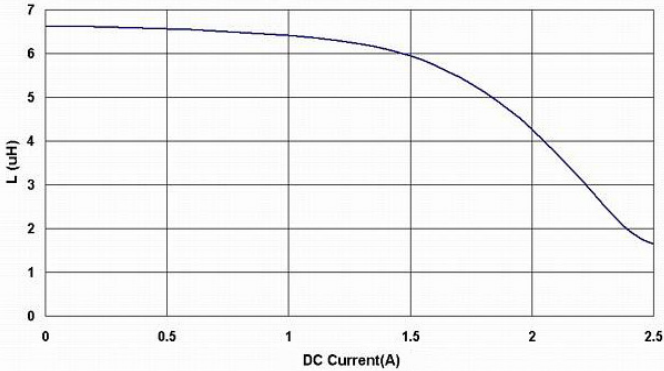

BPSC000606308R2□S0

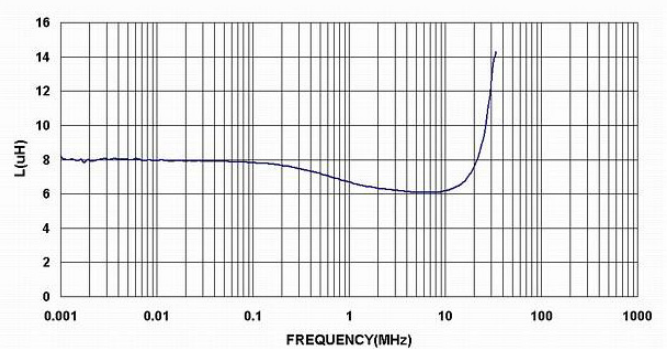
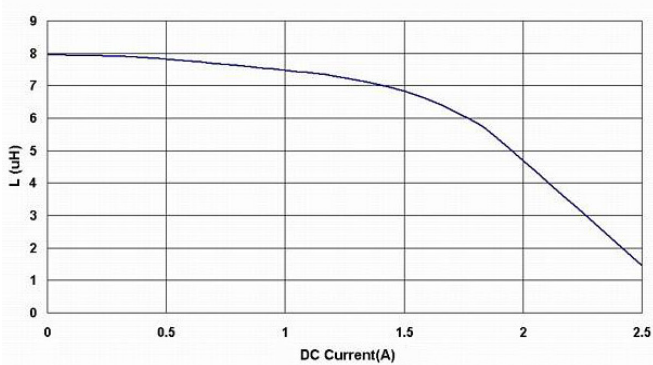

# BPSC00060630 Series Specification

**13** Graph:

BPSC00060630100□S0

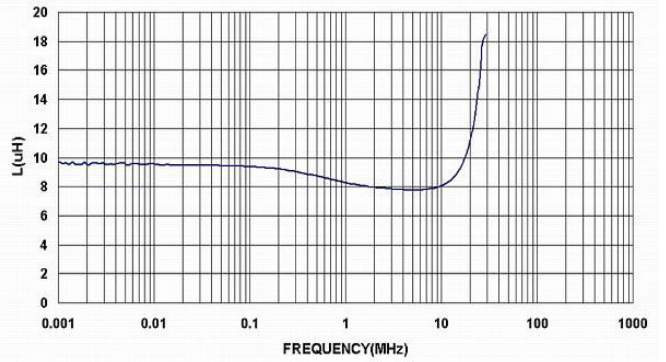
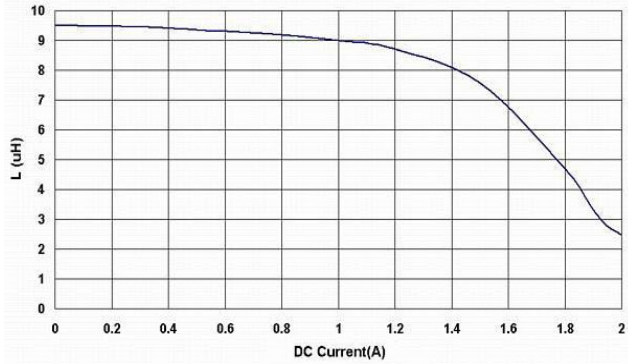

BPSC00060630120□S0

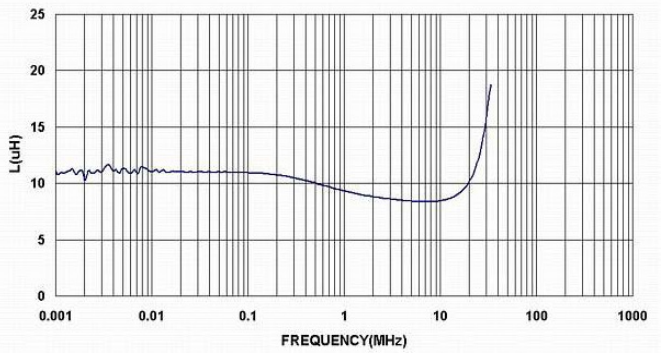
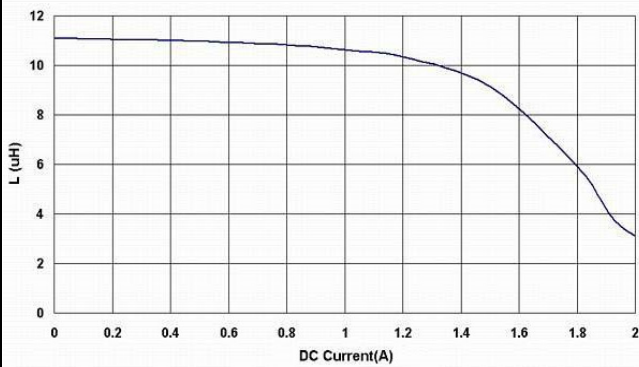

BPSC00060630150□S0

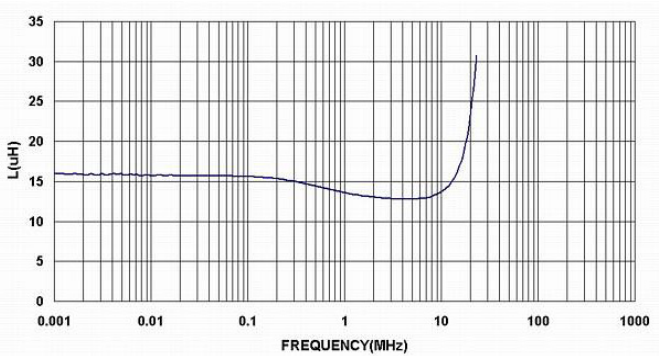
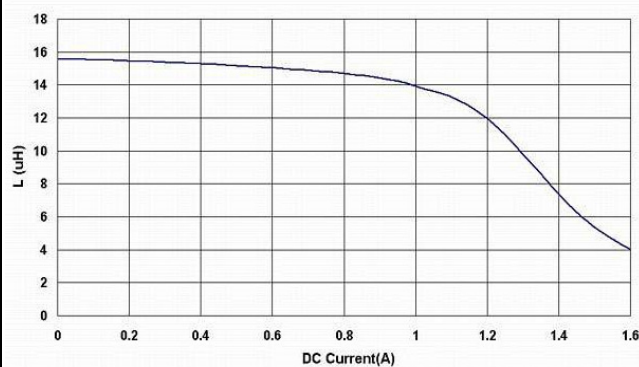

BPSC00060630180□S0

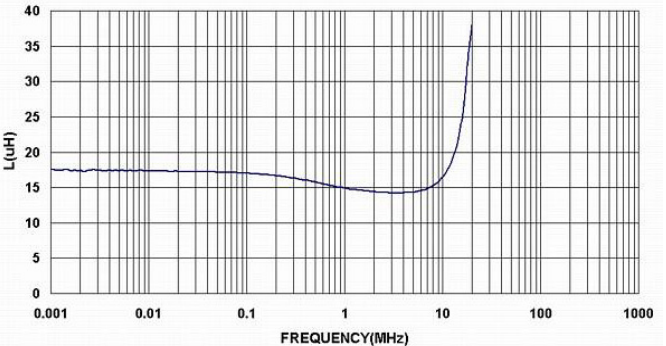
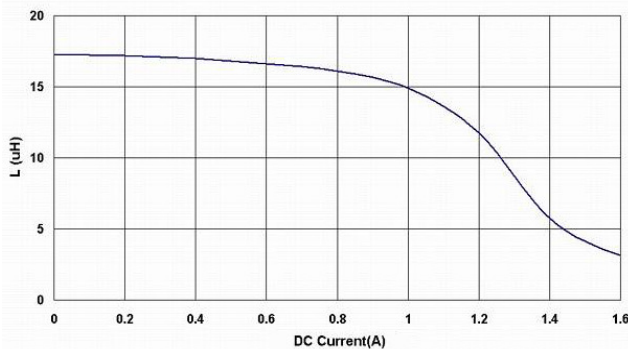

# BPSC00060630 Series Specification

**13** Graph:

BPSC00060630220□S0

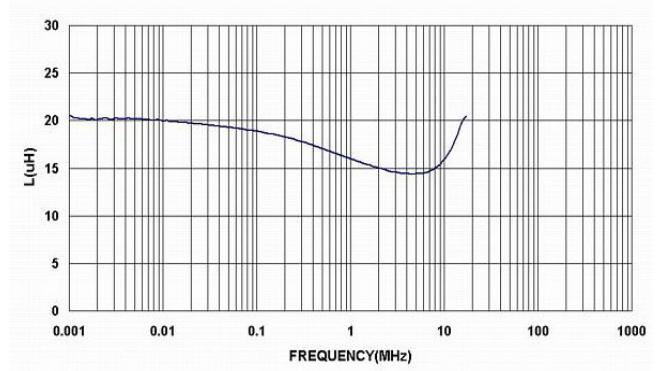
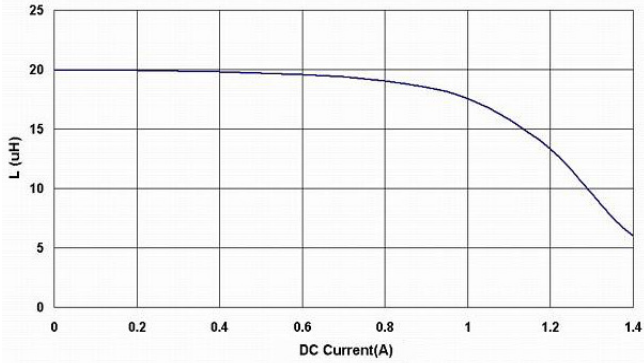

BPSC00060630270□S0

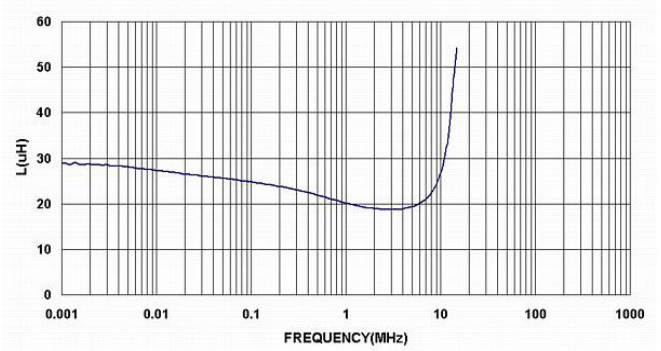
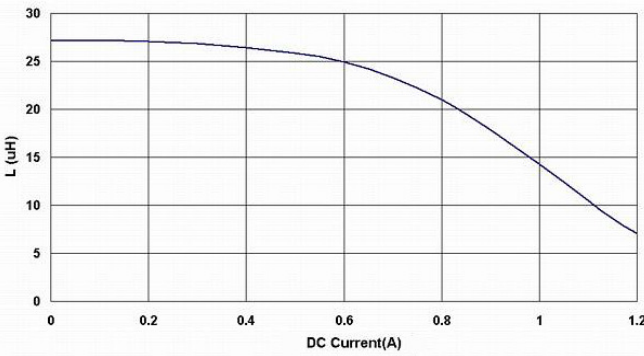

BPSC00060630330□S0

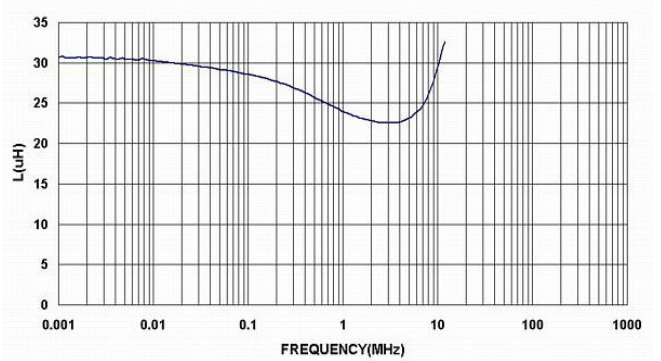
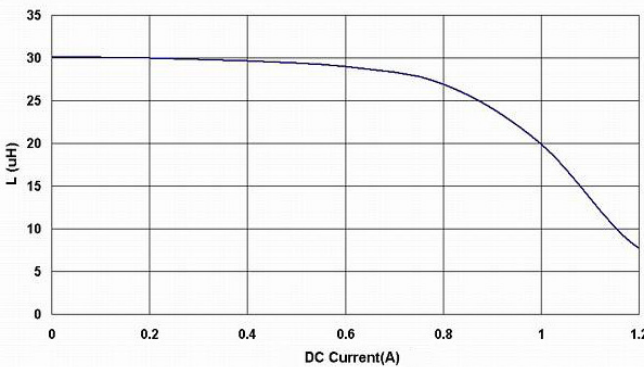

BPSC00060630390□S0

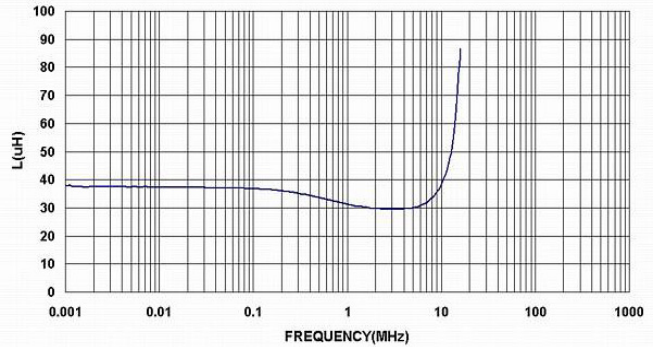
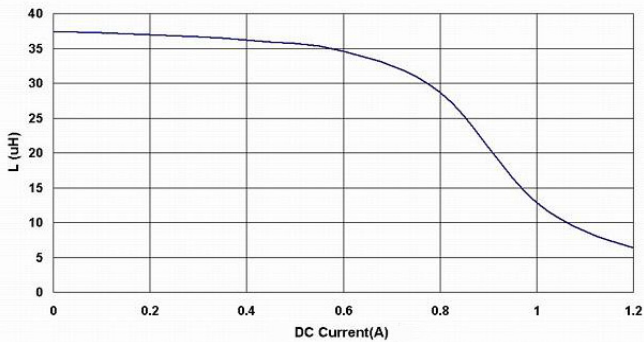

# BPSC00060630 Series Specification

**13** Graph:

BPSC00060630470□S0

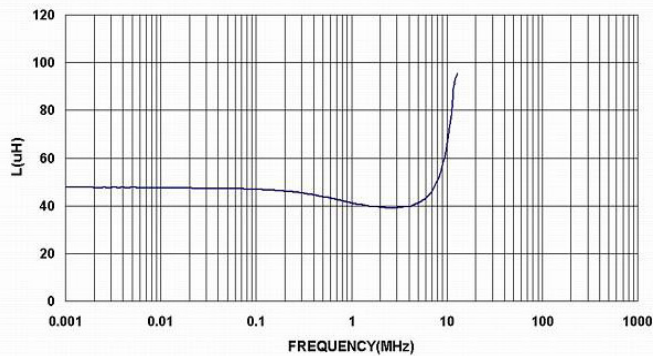
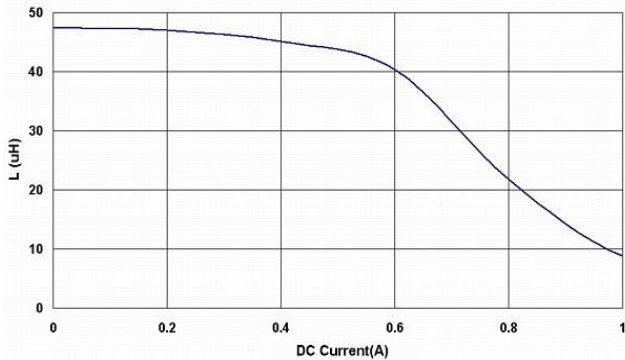

BPSC00060630560□S0

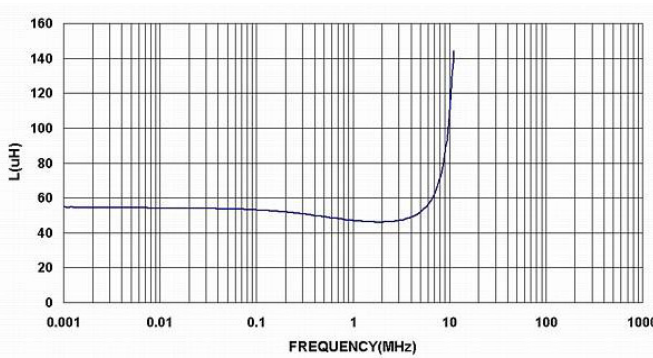
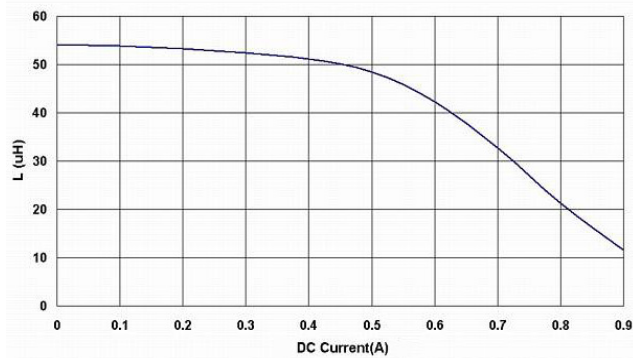

BPSC00060630680□S0

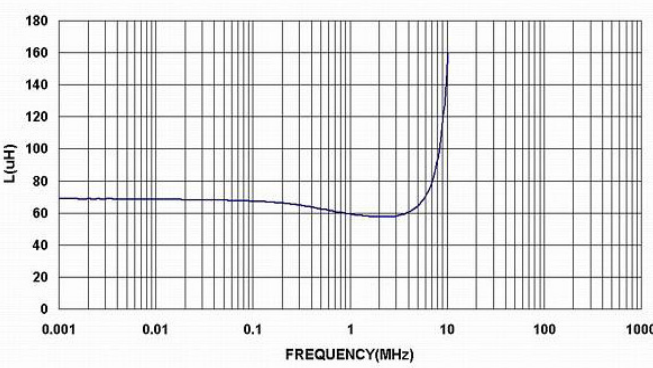
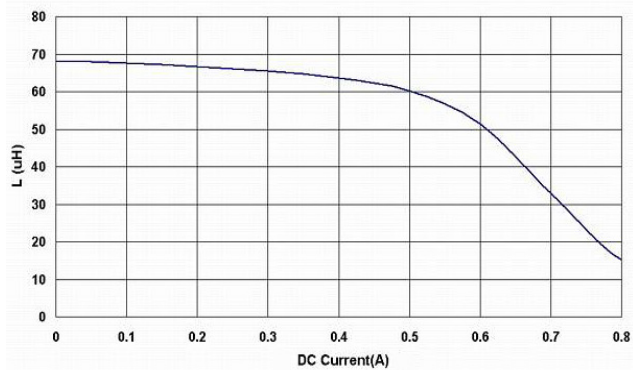

BPSC00060630820□S0

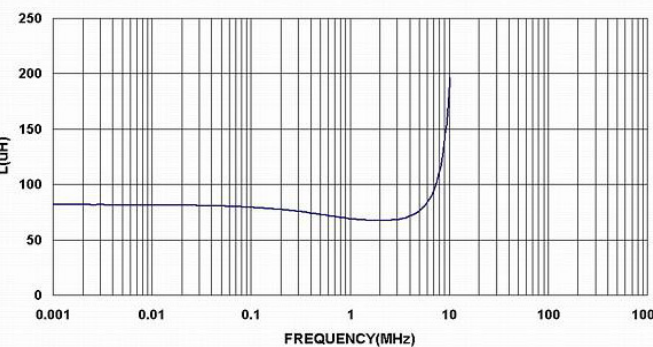
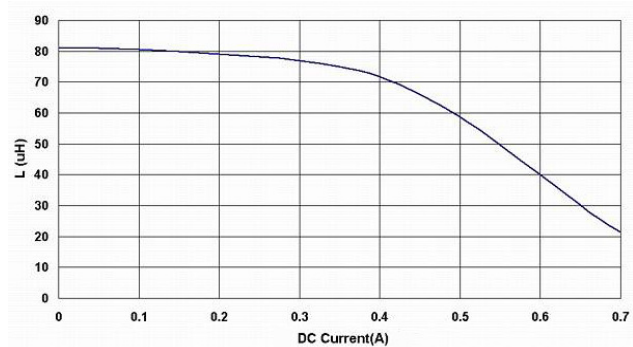

# BPSC00060630 Series Specification

**13** Graph:

BPSC00060630101□S0

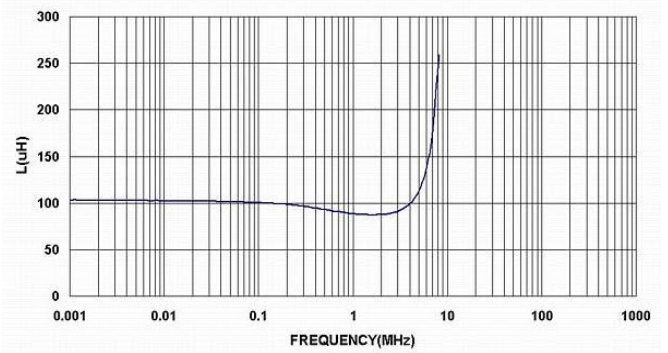
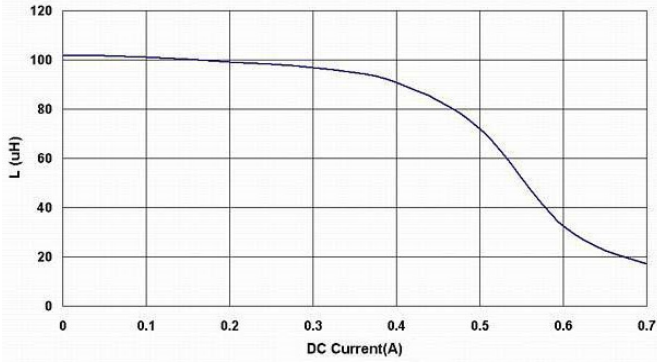

BPSC00060630181□S0

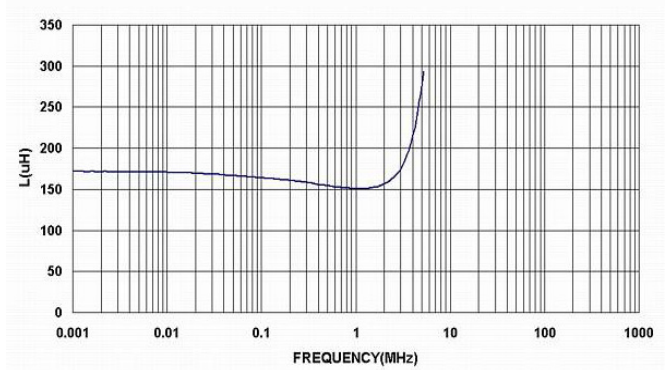
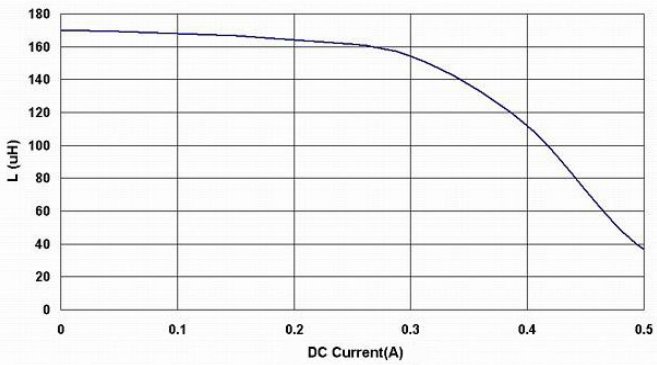

BPSC00060630221□S0

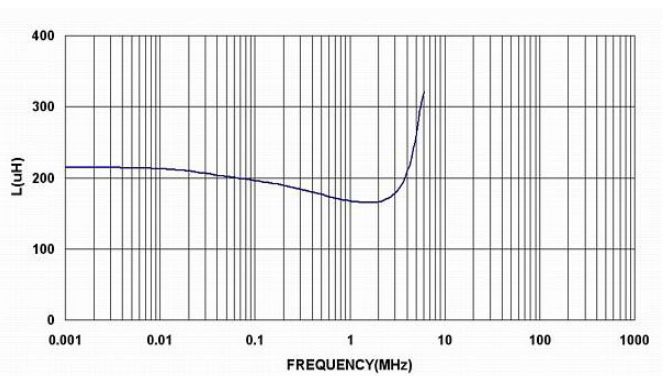
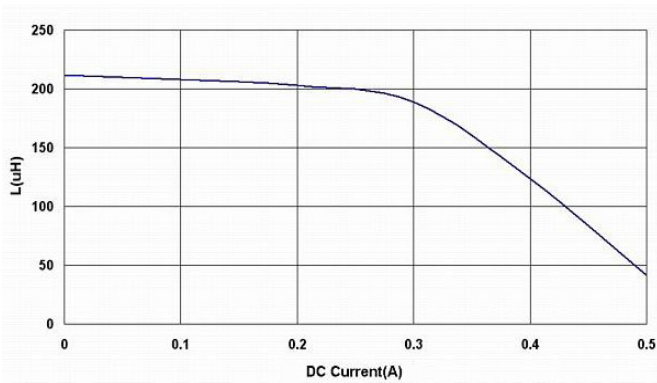

BPSC00060630331□S0

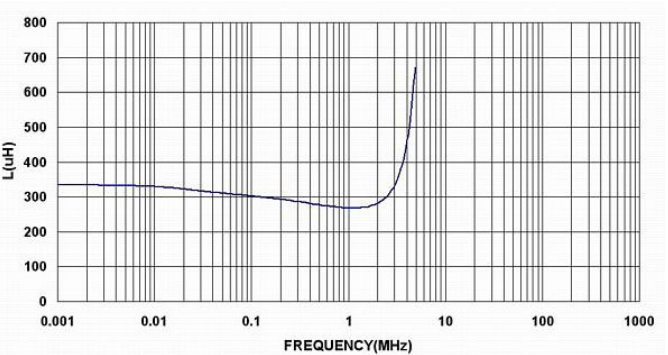
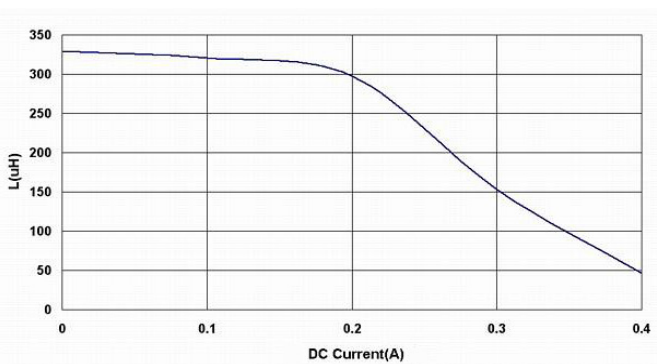

# BPSC00060630 Series Specification

**13** Graph:

BPSC00060630391 □ S0

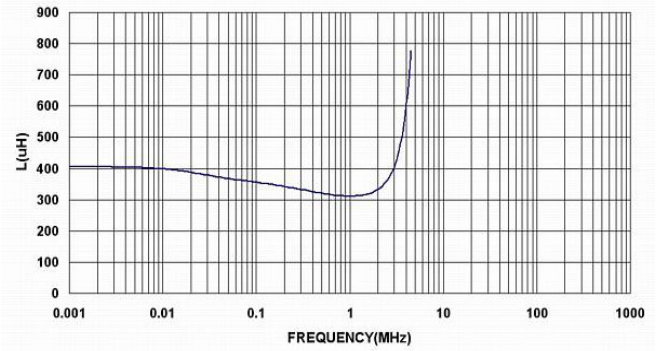
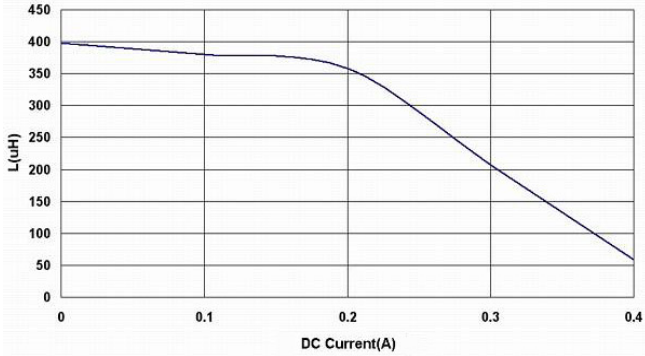

BPSC00060630471 □ S0

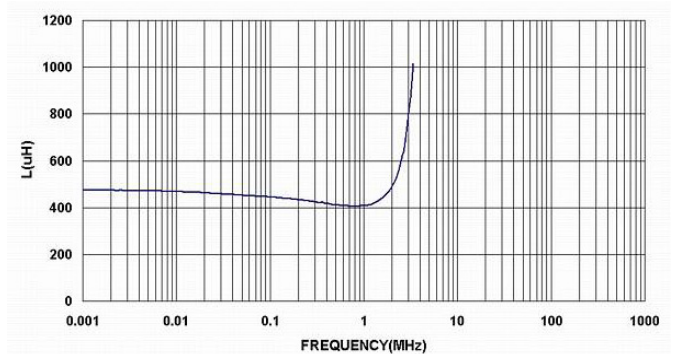
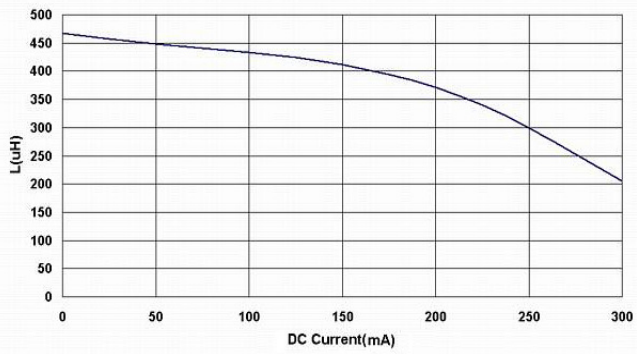

BPSC00060630561 □ S0

