

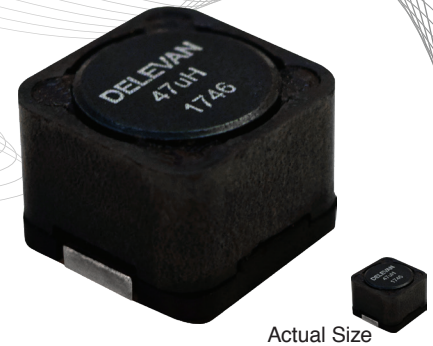

# HRSPD125

## Shielded Surface Mount Inductors High Reliability Applications



### Features and Benefits

Built to meet the following environmental requirements:

- High-Frequency Vibration: MIL-STD-202, Method 204 Test Condition D.
- Mechanical Shock: MIL-STD-202, Method 213 Test Condition I.
- Thermal Shock: MIL-PRF-27, -55°C to +130°C, 25 Cycles.
- Solderability: MIL-STD-202, Method 208.
- Burn-In: 96 Hours at 130°C.
- Moisture Resistance: MIL-STD-202, Method 106.
- Double Cycle SnPb Reflow Profile: MIL-PRF-83446, Section 4.6.18.
- +/-15% and +/-10% tolerances are available upon request.

### Parameters

**Current Rating at 90°C Ambient 40°C Temp Rise Maximum**

**Maximum Ambient Temperature 90°C**

**Operating Temperature Range -55°C to +130°C**

**Part Storage Temperature Range -55°C to +125°C**

**Maximum Power Dissipation at 90°C 0.560 Watts Maximum**

**Inductance** Measured at 1.0V AC at 100 kHz or 10 kHz

**Weight/Mass** 4.0 grams (0.14 ounces) Maximum

**Packaging** Tape and Reel (250 pieces max. / 13" reel)

### Core Material / Termination Finish

Ferrite Core and Shield

Sn 90 / Pb 10 Tinned Brass Leads

### Testing Level 1

Electrical Characteristics L, DCR

Country of Origin: Mexico

### Dimensions

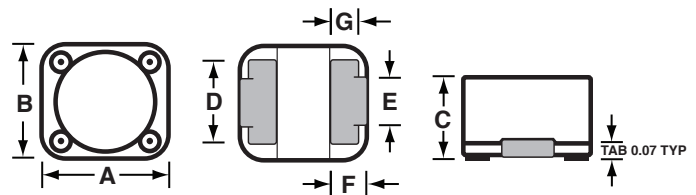

	Inches	Millimeters
A	0.475 ± 0.004	12.07 ± 0.10
B	0.475 ± 0.004	12.07 ± 0.10
C	0.283 maximum	7.02 maximum
D	0.340 ± 0.005	8.64 ± 0.13
E	0.175 ± 0.005	4.45 ± 0.13
F	0.130 ± 0.010	3.30 ± 0.25
G	0.110 ± 0.005	2.80 ± 0.13

Dimensions A and C are over terminals

### Suggested Land Pattern

	Inches	Millimeters
Z	0.535	13.59
G	0.190	4.83
X	0.350	9.14
Y	0.173	4.39
C	0.363	9.22

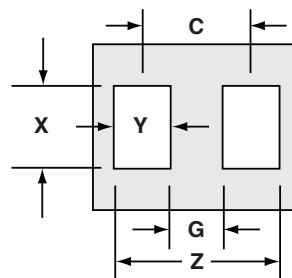



# HRSPD125

Shielded Surface Mount Inductors  
High Reliability Applications

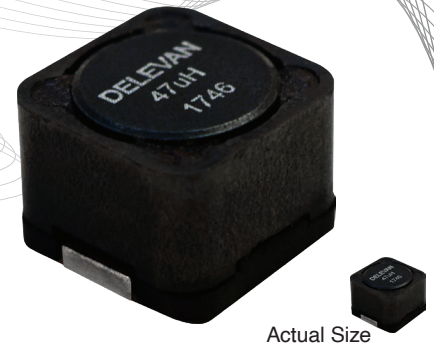

## FERRITE CORE

Part Number Prefix	Inductance (uH)	Percentage Tolerance (+/-)	Test Freq (kHz)	DCR Max (Ohms)	Incremental (Saturation) Current (AMPS DC) 10% Decrease in Inductance (Typical)	Rated Current (Amps)
HRSPD125-222M	2.2	20	100	0.010	11.27	7.50
HRSPD125-332M	3.3	20	100	0.012	9.54	7.00
HRSPD125-472M	4.7	20	100	0.014	7.29	5.70
HRSPD125-682M	6.8	20	100	0.017	6.53	5.30
HRSPD125-103M	10	20	100	0.030	5.39	4.00
HRSPD125-123M	12	20	100	0.034	4.96	3.60
HRSPD125-153M	15	20	100	0.046	4.28	3.10
HRSPD125-183M	18	20	100	0.052	4.00	2.90
HRSPD125-223M	22	20	100	0.068	3.54	2.50
HRSPD125-273M	27	20	100	0.078	3.18	2.30
HRSPD125-333M	33	20	100	0.088	2.88	2.20
HRSPD125-393M	39	20	100	0.110	2.64	2.00
HRSPD125-473M	47	20	100	0.125	2.43	1.90
HRSPD125-563M	56	20	100	0.140	2.25	1.80
HRSPD125-683M	68	20	100	0.155	2.03	1.70
HRSPD125-823M	82	20	100	0.175	1.85	1.60
HRSPD125-104M	100	20	10	0.225	1.65	1.40
HRSPD125-124M	120	20	10	0.260	1.53	1.30
HRSPD125-154M	150	20	10	0.290	1.36	1.20
HRSPD125-184M	180	20	10	0.330	1.25	1.10
HRSPD125-224M	220	20	10	0.420	1.12	1.00
HRSPD125-274M	270	20	10	0.480	1.01	0.95
HRSPD125-334M	330	20	10	0.680	0.92	0.80
HRSPD125-394M	390	20	10	0.900	0.84	0.70
HRSPD125-474M	470	20	10	1.050	0.77	0.65
HRSPD125-564M	560	20	10	1.250	0.71	0.58
HRSPD125-684M	680	20	10	1.450	0.65	0.55
HRSPD125-824M	820	20	10	1.800	0.58	0.49
HRSPD125-105M	1000	20	10	2.200	0.53	0.44

**Custom Inductance Values Available – Consult Factory**



# HRSPD125

Shielded Surface Mount Inductors  
High Reliability Applications

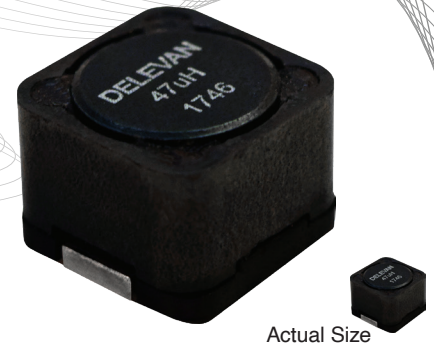

## Tape and Reel Specifications

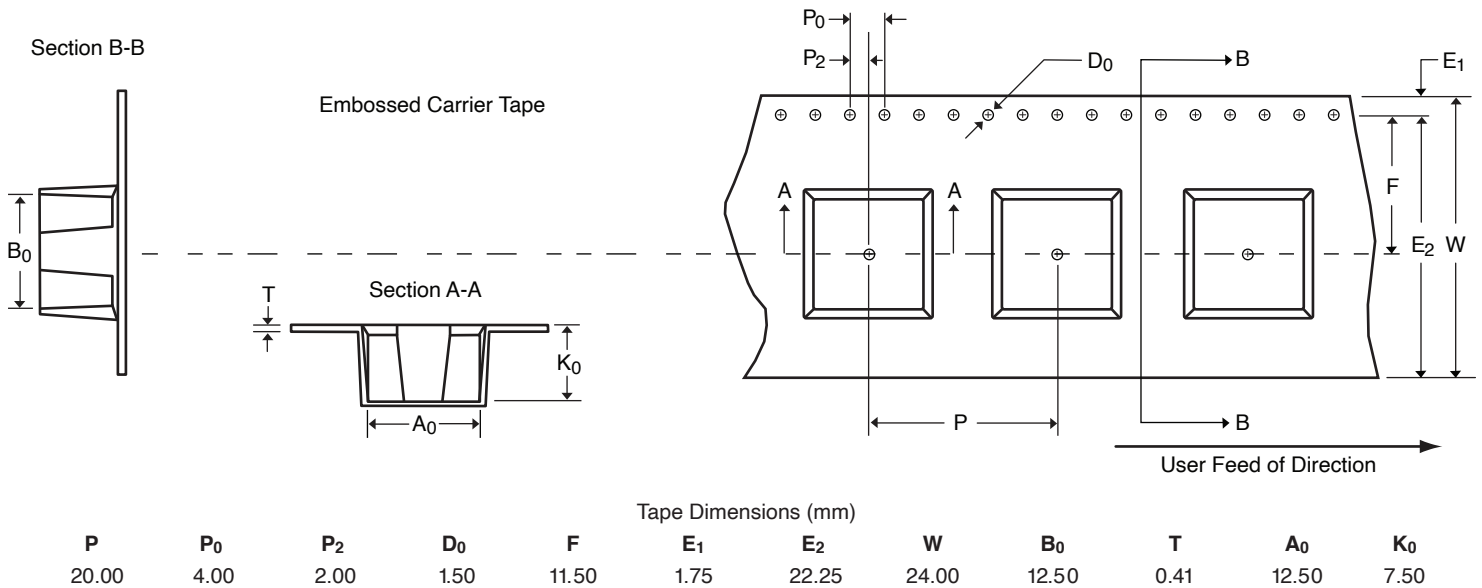

## Individual Part Marking

DELEVAN, Inductance Value, Date Code (YYWWL).

Part Marking Example: HRSPD125-473M  
DELEVAN  
47uH  
1746

## How To Order

<b>HRSPD125</b>	—	<b>473</b>	<b>M</b>
Inductor Series		Dash Number	Tolerance L = 15% K = 10%