

SMD Molded Power Inductors

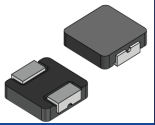

AMELA4012S Series

Request Samples



Check Inventory



4.3 x 4.1 x 1 mm

RoHS/RoHS II Compliant

MSL Level = 1

Features

- Low loss realized with low DCR.
- High Saturation current
- High performance realized by metal alloy core
- Ultra-low buzz noise, due to molded, composite construction.
- Fully Shielded component
- 100% Lead (Pb)-Free and RoHS compliant.

Applications

- DC/DC Switching power supplies
- Power supplies for Notebooks, workstations, and Servers
- Low Profile applications
- High current, transient load applications
- Consumer applications
- Medical applications
- Telecommunication

Electrical Specifications

Part Number	Inductance 0.1MHz/1.0V	Tolerance	DC Resistance		Irms		Isat		Marking
			Typ.	MAX	Typ.	MAX.	Typ.	MAX.	
Units	μ H	%	m Ω		A	A	A	A	
Symbol	L	M	DCR		Irms	Irms	Isat	Isat	
AMELA4012S-R47M	0.47	$\pm 20\%$	12.5	15.0	8.5	7.5	11.5	10.0	R47
AMELA4012S-R68M	0.68	$\pm 20\%$	17.5	21.0	7.3	6.8	10.0	9.0	R68
AMELA4012S-1R0M	1.00	$\pm 20\%$	22.5	27.0	6.6	6.0	8.2	7.2	1R0
AMELA4012S-1R5M	1.50	$\pm 20\%$	31.5	37.8	5.5	5.0	6.2	5.6	1R5
AMELA4012S-2R0M	2.00	$\pm 20\%$	39.0	46.8	5.0	4.5	5.7	5.2	2R0
AMELA4012S-2R2M	2.20	$\pm 20\%$	48.0	57.6	4.2	3.8	5.5	5.0	2R2
AMELA4012S-3R3M	3.30	$\pm 20\%$	76.0	91.2	3.6	3.1	4.2	3.7	3R3
AMELA4012S-4R7M	4.70	$\pm 20\%$	103.0	124.0	3.0	2.7	3.7	3.2	4R7
AMELA4012S-6R8M	6.80	$\pm 20\%$	133.0	160.0	2.6	2.3	3.0	2.6	6R8
AMELA4012S-8R2M	8.20	$\pm 20\%$	195.0	234.0	2.2	1.9	2.6	2.3	8R2
AMELA4012S-100M	10.0	$\pm 20\%$	217.0	260.0	1.9	1.7	2.3	2.1	100

Test conditions:

Test Frequency: 1.0V/100KHz

All test data referenced to 25°C ambient temperature.

Operating voltage: 40V Max.

Operating Temp.: -40°C to +125°C (including self-temperature rise)

Storage Temp.: -40°C to +125°C (on board)

Isat: DC current at which the inductance drops 30% from its value without current.

Irms: DC current that causes the temperature rise (ΔT , approximate 40 °C) from 25°C ambient.

Rated DC Current: The lower value of Irms and Isat

Part Temperature (Ambient + Temp. Rise): Should not exceed 125°C under worst case operating conditions.

Storage Condition (Component in its packaging)

Temperature: Less than 40°C

Humidity: Less than 85% RH



5101 Hidden Creek Ln, Spicewood TX 78669
Phone: 512-371-6159 Fax: 512-351-8858
For terms and conditions of sales, please visit:
www.abracon.com

REVISION Initial Release :
2/28/2025

ABRACON IS
ISO9001-2015
CERTIFIED

SMD Molded Power Inductors

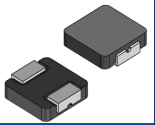

AMELA4012S Series

Request Samples



Check Inventory



4.3 x 4.1 x 1 mm
RoHS/RoHS II Compliant
MSL Level = 1

Part Identification

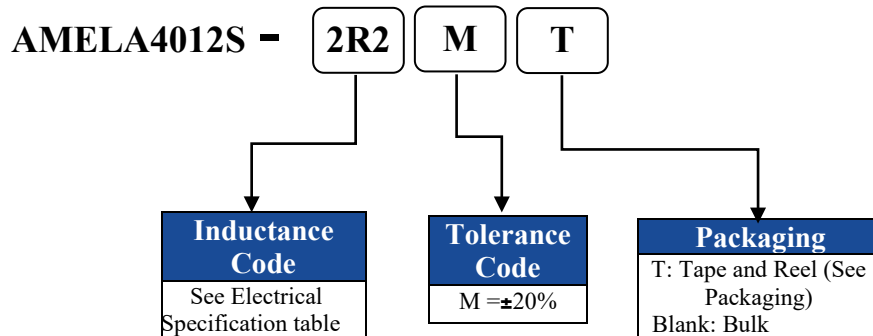

Performance Graphs

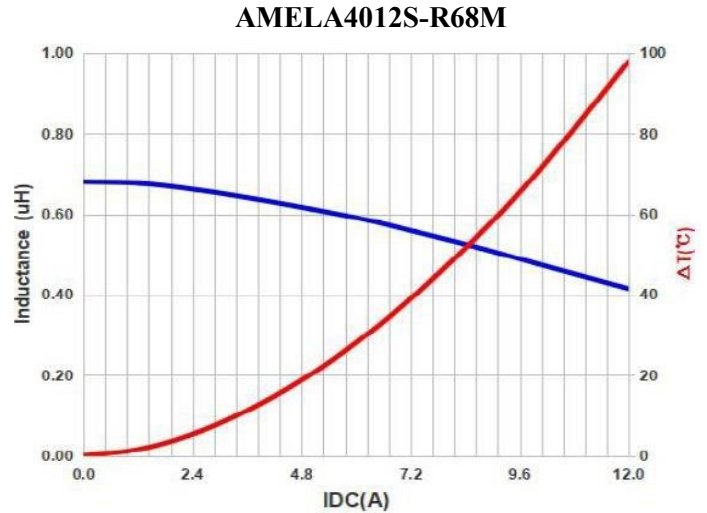
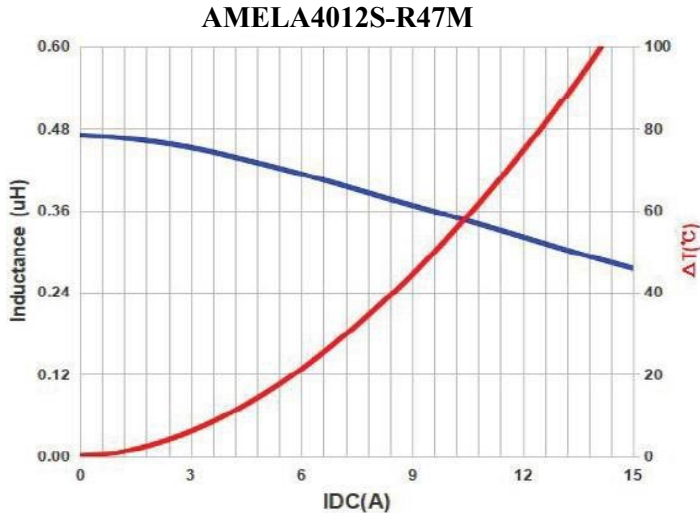

5101 Hidden Creek Ln, Spicewood TX 78669
Phone: 512-371-6159 Fax: 512-351-8858
For terms and conditions of sales, please visit:
www.abracon.com

REVISION Initial Release :
2/28/2025

ABRACON IS
ISO9001-2015
CERTIFIED

SMD Molded Power Inductors

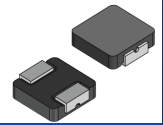

AMELA4012S Series

Request Samples



Check Inventory



4.3 x 4.1 x 1 mm
 RoHS/RoHS II Compliant
 MSL Level = 1

AMELA4012S-1R0M

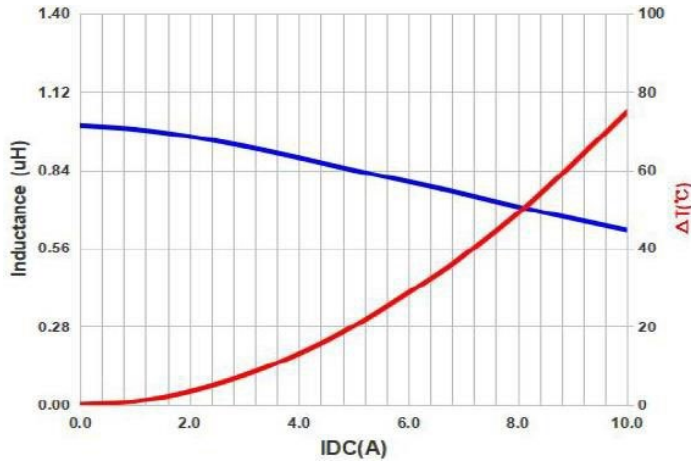

AMELA4012S-1R5M

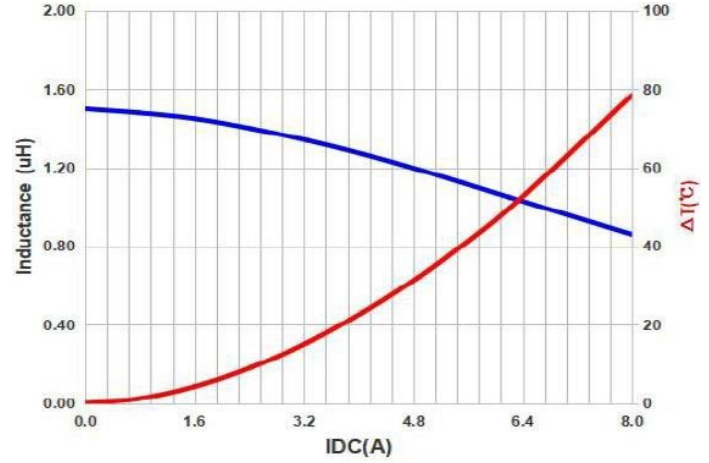

AMELA4012S-2R0M

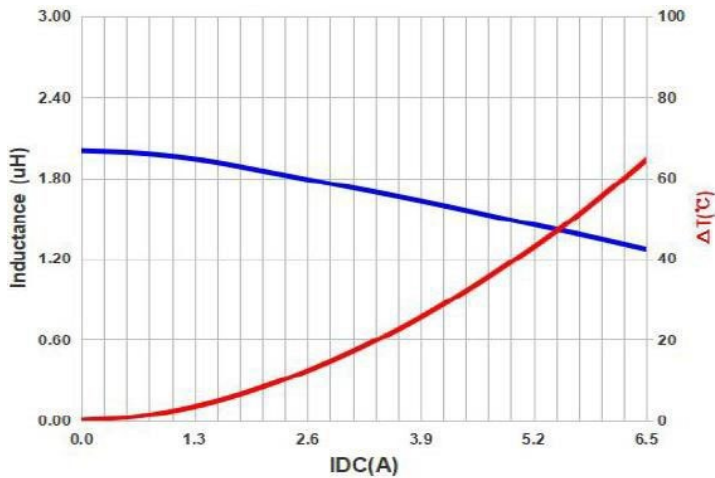

AMELA4012S-2R2M

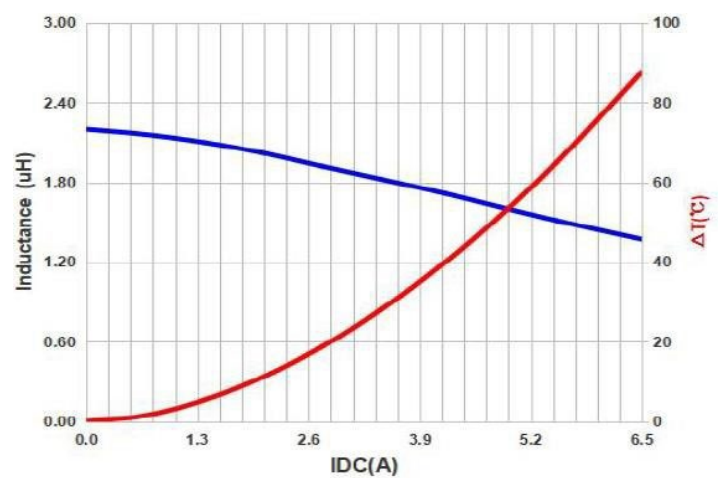

5101 Hidden Creek Ln, Spicewood TX 78669
 Phone: 512-371-6159 Fax: 512-351-8858
 For terms and conditions of sales, please visit:
www.abracon.com

REVISION Initial Release :
 2/28/2025

ABRACON IS
 ISO9001-2015
 CERTIFIED

SMD Molded Power Inductors

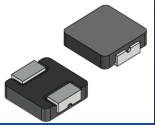

AMELA4012S Series

Request Samples



Check Inventory



4.3 x 4.1 x 1 mm
 RoHS/RoHS II Compliant
 MSL Level = 1

AMELA4012S-3R3M

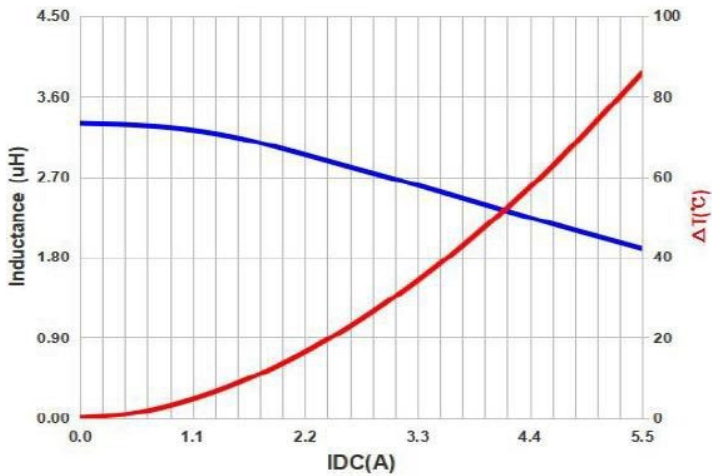

AMELA4012S-4R7M

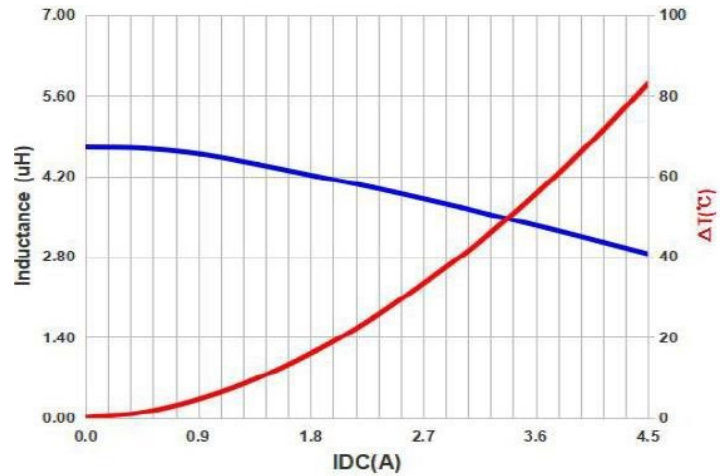

AMELA4012S-6R8M

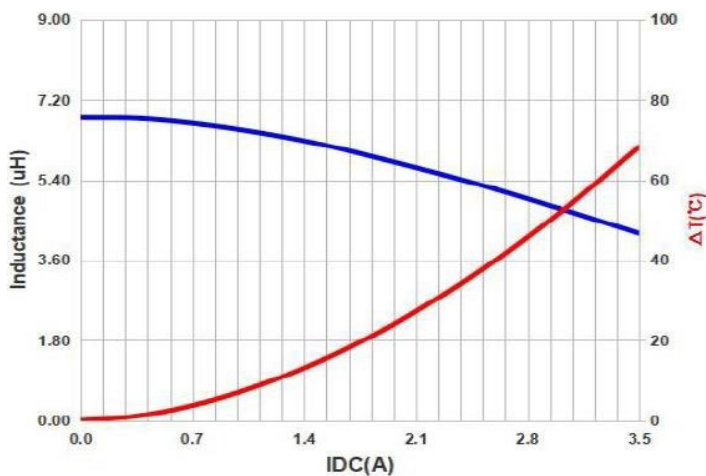

AMELA4012S-8R2M

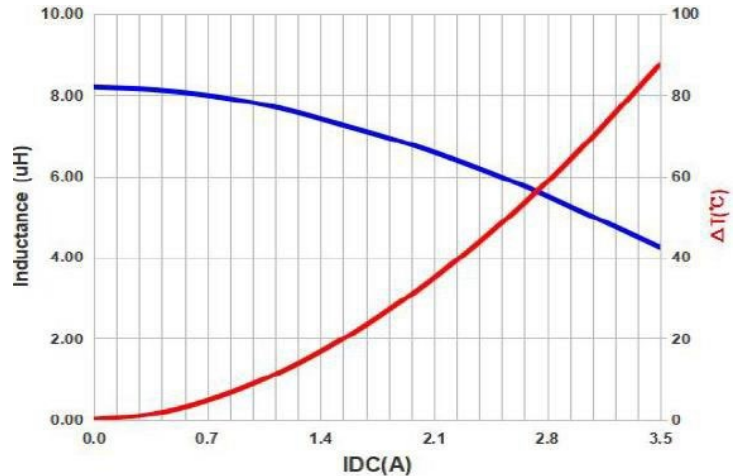

5101 Hidden Creek Ln, Spicewood TX 78669
 Phone: 512-371-6159 Fax: 512-351-8858
 For terms and conditions of sales, please visit:
www.abracon.com

REVISION Initial Release :
 2/28/2025

ABRACON IS
 ISO9001-2015
 CERTIFIED

SMD Molded Power Inductors

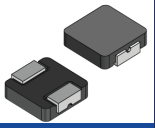

AMELA4012S Series

Request Samples



Check Inventory



4.3 x 4.1 x 1 mm
RoHS/RoHS II Compliant
MSL Level = 1

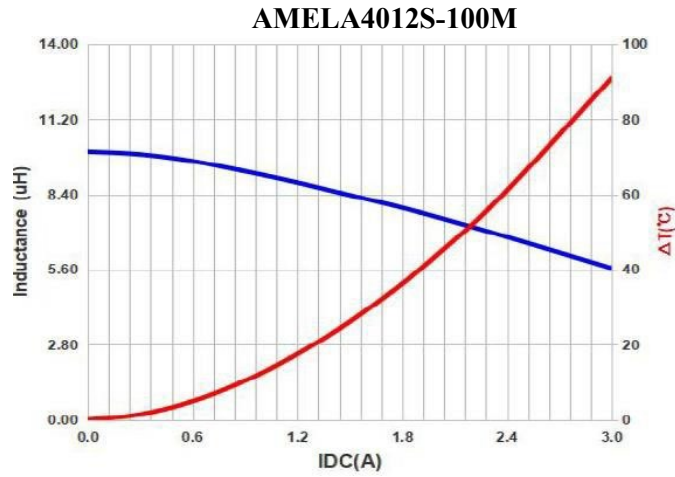

5101 Hidden Creek Ln, Spicewood TX 78669
Phone: 512-371-6159 Fax: 512-351-8858
For terms and conditions of sales, please visit:
www.abracon.com

REVISION Initial Release :
2/28/2025

ABRACON IS
ISO9001-2015
CERTIFIED

SMD Molded Power Inductors

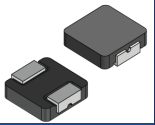

AMELA4012S Series

Request Samples



Check Inventory



4.3 x 4.1 x 1 mm
RoHS/RoHS II Compliant
MSL Level = 1

Mechanical Specifications

TOP VIEW

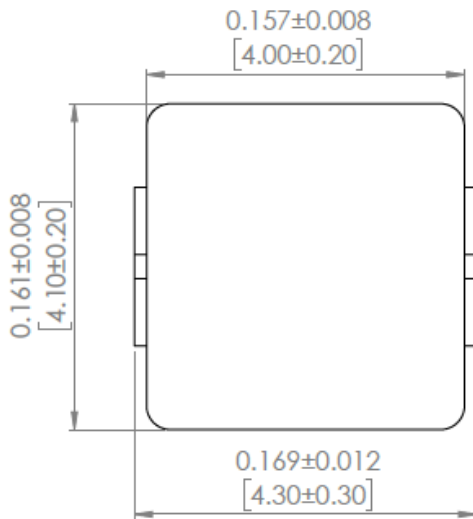

BOTTOM VIEW

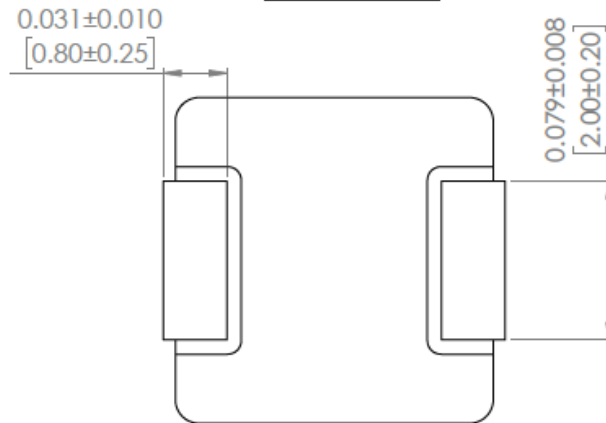

FRONT VIEW

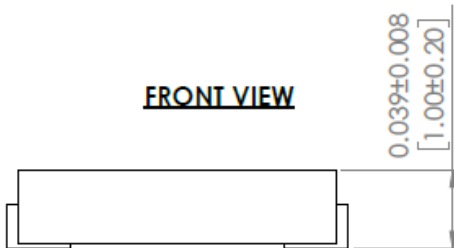

SIDE VIEW



RECOMMENDED LAND PATTERN

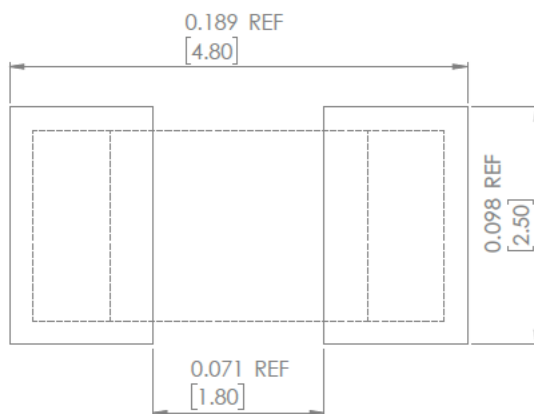

DIMENSIONS: INCHES[mm]

Notes:

- The above PCB layout reference only.
- Recommend solder paste thickness at 0.12mm and above.

SMD Molded Power Inductors

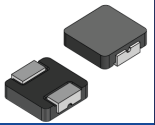

AMELA4012S Series

Request Samples



Check Inventory



4.3 x 4.1 x 1 mm

RoHS/RoHS II Compliant

MSL Level = 1

Materials

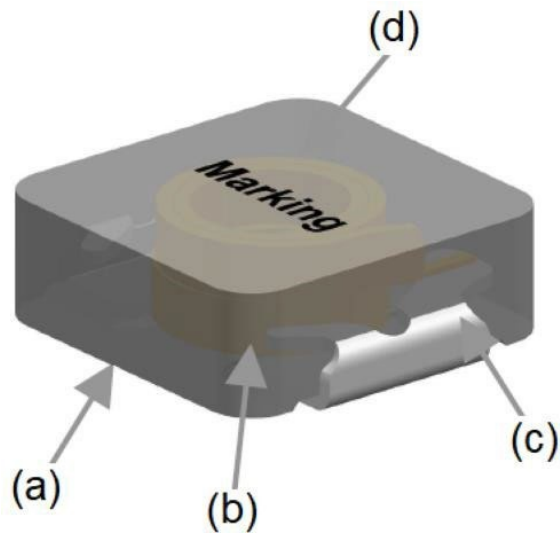

- (a) Core
- (b) Wire
- (c) Clip
- (d) Ink

Components	Material
Core	Metal Alloy
Wire	Polyester Wire
Clip	100% Pb free solder (Ni+Sn Plating)
Ink	Halogen-free ketone

Schematic:

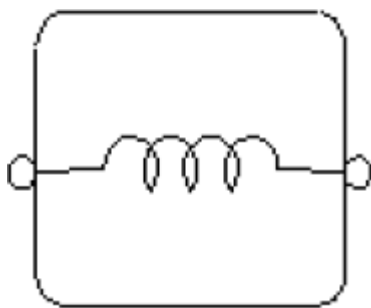

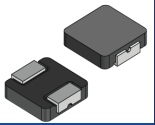

AMELA4012S Series

Request Samples



Check Inventory



4.3 x 4.1 x 1 mm
RoHS/RoHS II Compliant
MSL Level = 1

Reflow Profile

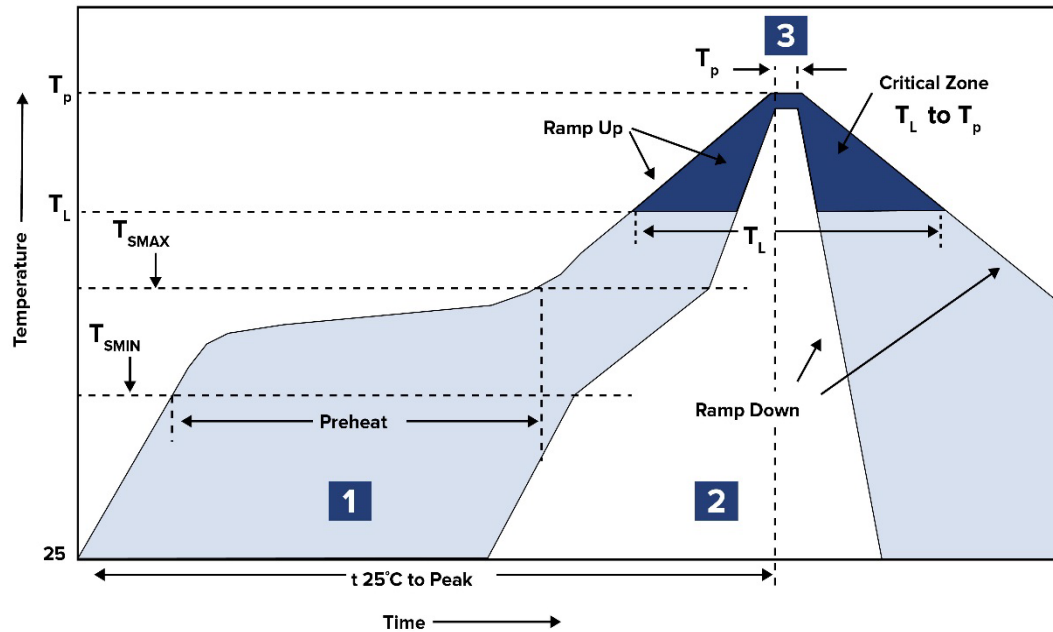

Zone	Description	Temperature	Times
1	Preheat	$T_{SMIN} \sim T_{SMAX}$ 150°C ~ 200°C	60 ~ 120 sec.
2	Reflow	T_L 217°C	60 ~ 150 sec.
3	Peak heat	T_P 255°C	< 30 seconds

Ref.

Solder paste: Sn/3.0Ag/0.5Cu

Ramp up rate: 3°C/s Max.

Ramp down rate: 6°C/s Max.

Reflow is referred to standard IPC/JEDEC J-STD-020E.

Reflow times: 3 times maximum

SMD Molded Power Inductors

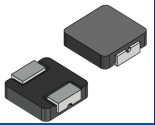

AMELA4012S Series

Request Samples



Check Inventory



4.3 x 4.1 x 1 mm
RoHS/RoHS II Compliant
 MSL Level = 1

Packaging

Tape & Reel: 4000 pcs/reel

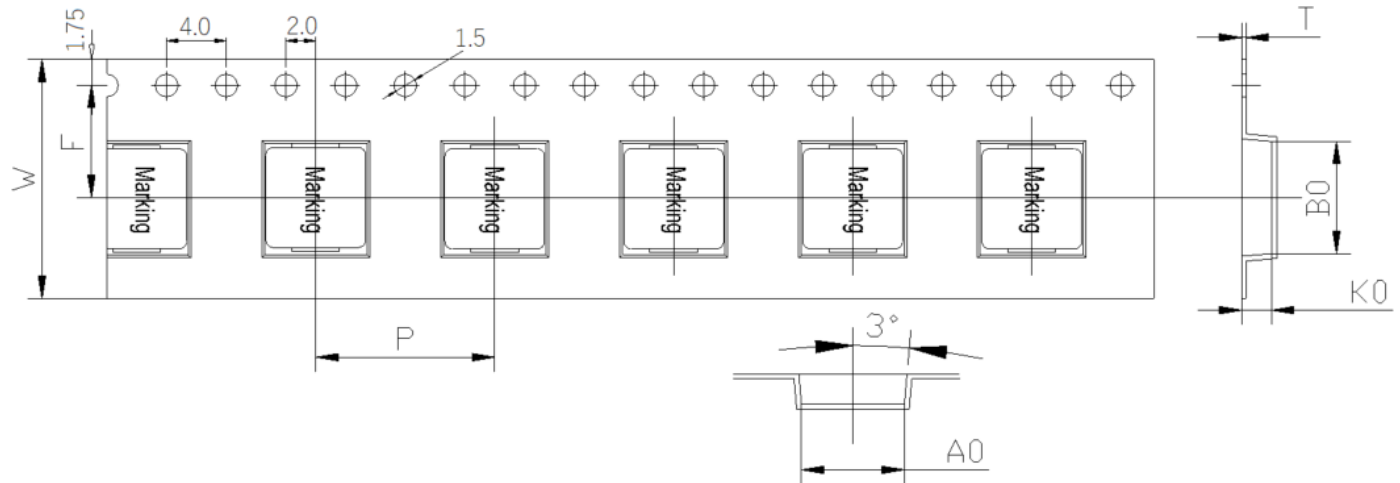

B0	A0	K0	P	W	F	T
5.00±0.10	4.40±0.10	1.30±0.10	8.00±0.10	12.00±0.30	5.50±0.10	0.35±0.05

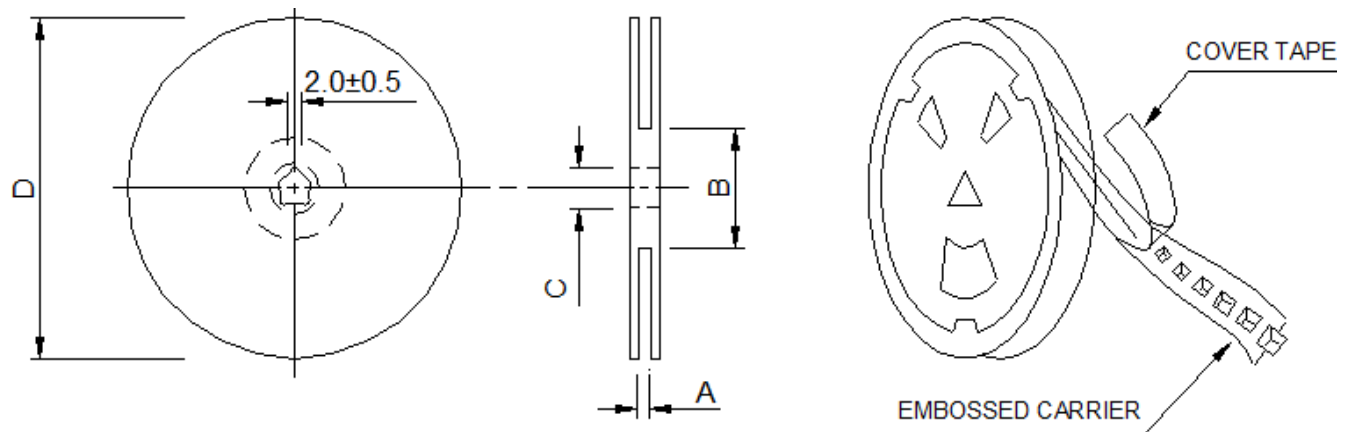

Type	A	B	C	D
13"x12mm	12.4+2.0/-0.0	100.0±2.0	13.0+0.5/-0.2	330.0

Dimensions: mm

ATTENTION: Abracon LLC's products are Commercial-Off-The-Shelf (COTS), which are designed, intended and validated for use in commercial, industrial and automotive applications. The customer is responsible for testing and verifying the performance of an Abracon solution to meet their system-level requirements.



5101 Hidden Creek Ln, Spicewood TX 78669
 Phone: 512-371-6159 Fax: 512-351-8858
 For terms and conditions of sales, please visit:
www.abracon.com

REVISION Initial Release :
 2/28/2025

ABRACON IS
 ISO9001-2015
 CERTIFIED